

TECVISION

USER / INSTALLER GUIDE 2 READER SYSTEM

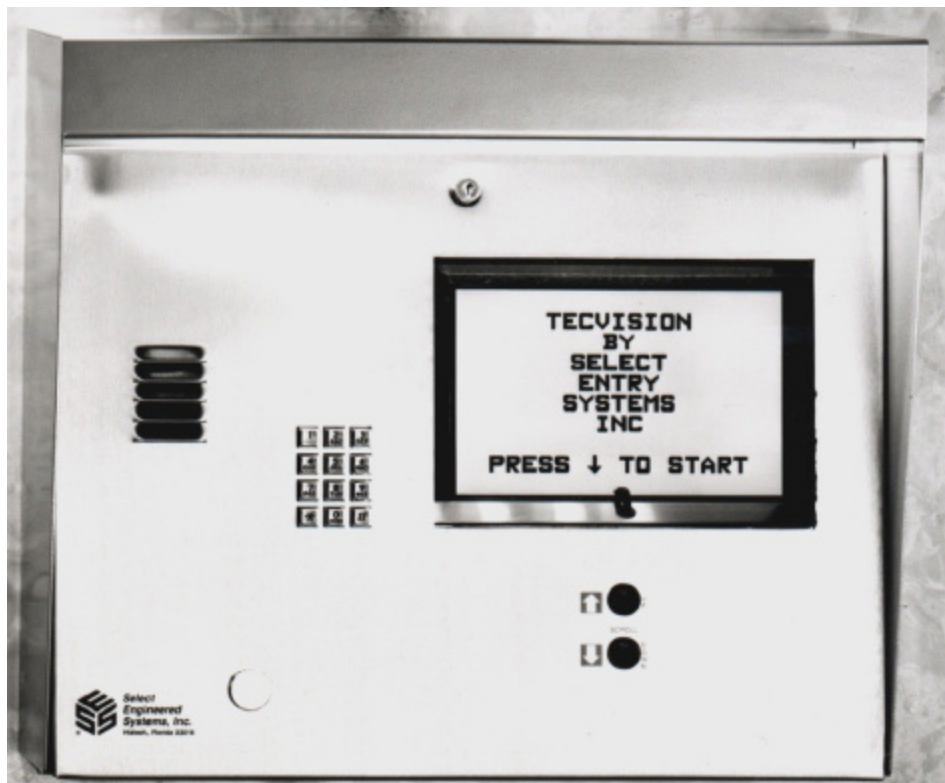

Select Entry Systems



COVERS FIRMWARE
REVISIONS
3.10, 3.11, 3.12

TABLE OF CONTENTS

1.0	INTRODUCTION TEC SERIES	1
1.1	STANDARD FEATURES	2
1.2	SPECIAL STANDARD FEATURES	2
1.3	OPTIONS	3
1.4	ENVIRONMENTAL CONSIDERATIONS	4
1.5	ELECTRICAL	4
1.6	TECHNICAL DATA	4
2.0	INSTALLATION INSTRUCTIONS	5
2.1	INSTALLATION PRODECURE	5
3.0	WIRING HOOKUP CONNECTIONS	7
3.1	TERMINAL BARRIER STRIP CONNECTIONS	8
3.2	RELAY JUMPER SELECTION	9
4.0	SETUP AND PROGRAMMING	10
4.0.1	QUICK PROGRAMMING EXAMPLE	10
4.1	SETUP	11
4.1.1	MANAGER PASSCODE	12
4.2	PROGRAMMING CHOICES	13
4.2.1	CODES / NAMES	15
4.2.1.1	ADD / FIND NAME	15
4.2.1.1A	DELETING A CODE	15
4.2.1.1B	DELETING A CODE FIELD	15
4.2.1.2	FIND NAME	17
4.2.1.3	FIND PIN	17
4.2.1.4	FIND CARD	18
4.2.1.5	CODES USED	18
4.2.1.6	SHOW ALL CODES	18
4.2.1.7	SHOW ALL NAMES	18
4.2.1.8	ENABLE ACCESS GROUPS	18
4.2.2	ENTRY CONTROL	19
4.2.2.1	ENTRANCE 1 UNLOCK TIME	19
4.2.2.2	ENTRANCE 1 UNLOCK TONE	19
4.2.2.3	ENTRANCE 1 AUTO GROUP	19
4.2.2.4	ENTRANCE 1 LATCH TONE	19
4.2.2.5	ENTRANCE 1 AJAR TIME	20
4.2.2.6	ENTRANCE 2 UNLOCK TIME	20
4.2.2.7	ENTRANCE 2 UNLOCK TONE	20
4.2.2.8	ENTRANCE 2 AUTO GROUP	20
4.2.2.9	ENTRANCE 2 LATCH TONE	20
4.2.2.10	ENTRANCE 2 AJAR TIME	20
4.2.3	SYSTEM PARAMETERS	21
4.2.3.1	TALK TIME	21
4.2.3.2	ALARM TIME	22
4.2.3.3	CODE LENGTH	22
4.2.3.4	PIN LENGTH	22
4.2.3.5	BACK BEEP	22
4.2.3.6	TONE DIAL	22
4.2.3.7	RING COUNT	22
4.2.3.8	STRIKE OUTS	22
4.2.3.9	TITLE PAGE	23

TABLE OF CONTENTS

4.2.4	COMMUNICATIONS SETUP	24
4.2.4.1	TERMINAL TYPE	24
4.2.4.2	RS 232 BAUD	24
4.2.4.3	PROGRAM PASSWORD	24
4.2.4.3A	CONTROL PASSWORD	24
4.2.4.4	PIN ON ENTRANCE	25
4.2.4.5	SITE CODE	25
4.2.4.6	TV LCD CONFIGURATION	25
4.2.4.7	KEYPAD ON / OFF	25
4.2.4.8	SPEAKER TONE	25
4.2.4.9	UPDATE LCD	25
4.2.5	CLOCK SETUP	26
4.2.5.1	SETTING TIME/DATE	26
4.2.5.2	SETTING TIME ZONES	27
4.2.5.3	SETTING HOLIDAYS	28
4.2.6	ACCESS CONTROL	29
4.2.6.0	ACCESS GROUPS	30
4.2.6.1	SELECTING AN ACCESS GROUP	30
4.2.6.2	SELECTING AN ACCESS LEVEL	30
4.2.6.2.0	ACCESS LEVELS	30
4.2.6.2.1	PROGRAMMING AN ACCESS LEVEL	31
4.2.6.2.2	SELECTING A TIME ZONE	31
4.2.6.2.3	SELECTING A DOOR	31
4.2.6.3	AUTOMATIC UNLOCK AND RELOCK BY TIME ZONE	31
4.2.6.3.1	EXAMPLE OF AN AUTOMATIC UNLOCK APPLICATION	32
4.2.7	TRANSACTION BUFFER INFORMATION	32
4.2.7.1	VIEW LOG	33
4.2.7.2	SEND LOG	33
4.2.7.3	FIND CODE	33
4.2.7.4	LOG SIZE	33
4.2.7.5	CLEAR BUFFER	33
4.2.8	CLEAR DATA	34
4.2.8.1	SET PARAMETERS	34
4.2.8.2	CLEAR TIME ZONES	34
4.2.8.3	CLEAR HOLIDAYS	34
4.2.8.4	CLEAR ACCESS LEVELS	34
4.2.8.5	CLEAR ACCESS GROUPS	34
4.2.8.6	CLEAR CORRUPT DATA	34
4.2.9	DISPLAY DATA	34
4.2.9.1	PRINT INFO	35
4.2.9.2	PRINT TIME ZONES	35
4.2.9.3	PRINT HOLIDAYS	35
4.2.9.4	PRINT ACCESS LEVELS	36
4.2.9.5	PRINT ACCESS GROUPS	36
4.2.9.6	DISPLAY TIME ZONES	36
4.2.9.7	DISPLAY HOLIDAYS	36
4.2.9.8	DISPLAY ACCESS LEVELS	36
4.2.9.9	DISPLAY ACCESS GROUPS	36
5.0	S1 SWITCH SELECTION DESCRIPTIONS	37
5.1	SPEAKER AND MIKE ADJUSTMENTS	37
5.2	POWER SWITCH LOCATION	38

TABLE OF CONTENTS

6.0 REMOTE CONTROL OF TEC 39

6.1 REMOTELY ACTIVATING OUTPUT RELAYS 39

 6.1.1 REMOTELY ACTIVATING PRIMARY RELAY (TIMED) 39

 6.1.2 REMOTELY ACTIVATING PRIMARY RELAY (LATCHED) 39

 6.1.2.1 REMOTELY UNLATCHING PRIMARY RELAY (LATCHED) 39

 6.1.3 REMOTELY ACTIVATING ENTRANCE RELAYS 2 OR 3 (TIMED) 40

 6.1.4 REMOTELY ACTIVATING ENTRANCE RELAYS 2 OR 3 (LATCHED) 40

 6.1.4.1 REMOTELY UNLATCHING ENTRANCE RELAYS 2 OR 3 (LATCHED) 40

 6.1.5 REMOTELY OPENING MIKE/SPEAKER CHANNEL 40

7.0 TECVISION BULBS 41

8.0 ACCESSORIES OVERVIEW 42

9.0 CARDS 44

9.1 CARD READER VOLTAGE SELECT 44

9.2 GROUNDING CARD READER WIRING 45

9.3 CONNECTING CARD READER WIRING 46

9.4 SITE CODE 46

9.5 SETTING WIEGAND FORMAT 46

10.0 MUI 47

11.0 GROUND START 47

12.0 OPTK2R RELAY MODULE 48

13.0 K3 CONTROL RELAY 50

 13.1 K3 AS A THIRD ENTRANCE 51

 13.2 ENTRANCE 3 PROGRAMMING 51

 13.2.1 ENTRANCE 3 UNLOCK TIME 51

 13.2.2 ENTRANCE 3 UNLOCK TONE 51

 13.2.3 ENTRANCE 3 AUTO GROUP 51

 13.2.4 ENTRANCE 3 LATCH TONE 52

 13.2.5 ENTRANCE 3 AJAR TIME 52

 13.2.1 ENTRANCE 3 WIRING 53

14.0 SERIAL PORT ADAPTER 54

14.1 PRINTER 54

 14.1.1 PRINTER REPORTS AND MESSAGES 55

14.2 CONNECTING A PERSONAL COMPUTER TO THE SERIAL PORT 56

14.3 TERMINAL 57

14.4 CURRENT LOOP 58

15.0 1200 BAUD MODEM 59

15.1 9600 BAUD MODEM 59

15.2 MODEM COMMUNICATIONS 60

15.3 COMPUTERS WITH OTHER TERMINAL PROGRAMS 60

15.4 FAX / MODEMS 61

15.5 TWO MINUTE LOCKOUT 61

TECVISION Series v 3.1X

I. FCC REQUIREMENTS

1. The Federal Communications Commission (FCC) has established Rules which permit this device to be directly connected to the telephone network. Standardized jacks are used for these connections. This equipment should not be used on party lines or coin lines.
2. If this unit is malfunctioning, it may also be causing harm to the telephone network. This device should be disconnected until the source of the problem can be determined and until repair has been made. If this is not done, the telephone company may temporarily disconnect service.
3. The telephone company may make changes in its technical operations and procedures. If such changes affect the compatibility or use of this device, the telephone company is required to give adequate notice of the changes. You will be advised of your right to file a complaint with the FCC.
4. If the telephone company requests information on what equipment is connected to their lines, inform them of:
 - a. The telephone number this unit is connected to
 - b. The ringer equivalence number
 - c. The USOC jack required
 - d. The FCC Registration number

Items `b' and `d' are indicated on the label.

The ringer equivalence (REN) is used to determine how many devices can be connected to your telephone line. In most areas, the sum of the RENs of all devices on any one line should not exceed five (5.0). If too many devices are attached, they may not ring properly.

II. SERVICE REQUIREMENTS

1. In the event of equipment malfunction, all repairs should be performed by our Company or an authorized agent. It is the responsibility of users requiring service to report the need for service to our Company or to one of our authorized agents. Service can be obtained at:

Phone: _____

Warning: Changes or modifications not expressly approved by the party responsible for compliance could void the user's authority to operate the equipment.

NOTE: This Equipment has been tested and found to comply with the limits for a Class A digital device. This is pursuant to Part 15 of the FCC Rules. These limits are designed to provide reasonable protection against harmful interference when the equipment is operated in a commercial environment. This equipment generates, uses and can radiate radio frequency energy. If not installed and used in accordance with the instruction manual, may cause harmful interference to radio communications. Operation of this equipment in a residential area is likely to cause harmful interference. If this is the case, the user will be required to correct the interference at his own expense.

NOTICE: The Canadian Department of Communications label identifies certified equipment. This certification means that the equipment meets certain telecommunications network protective, operational and safety requirements. The Department does not guarantee the equipment will operate to the user's satisfaction.

Before installing this equipment, users should ensure that it is permissible to be connected to the facilities of the local telecommunications company. The equipment must also be installed using an acceptable method of connection. In some cases, the company's inside wiring associated with a single line individual service may be extended by means of a certified connector assembly (telephone extension cord). The customer should be aware that compliance with the above conditions may not prevent degradation of service in some situations.

Repairs to certified equipment should be made by an authorized Canadian maintenance facility designated by the supplier. Any repairs or alterations made by the user to this equipment, or equipment malfunctions, may give the telecommunications company cause to request the user to disconnect the equipment.

Users should ensure for their own protection that the electrical ground connections of the power utility, telephone lines and internal metallic water pipe system, if present, are connected together. This precaution may be particularly important in rural areas.

Caution: Users should not attempt to make such connections themselves, but should contact the appropriate electric inspection authority, or electrician, as appropriate.

The Load Number (LN) is assigned to each terminal device. This denotes the percentage of the total load to be connected to a telephone loop which is used by the device, to prevent overloading. The termination on a loop may consist of any combination of devices. This is subject only to the requirement that the total Load Numbers of all the devices does not exceed 100.

This digital apparatus does not exceed the Class A limits for radio noise emissions from digital apparatus. This is set out in the Radio Interference Regulations of the Canadian Department of Communications.

Le present appareil numerique n'emet pas de bruits radioelectriques depassant les limites applicables aux appareils numeriques de la Class A pescries dans le Reglement sur le brouillage radioelectrique edicte par le ministere des Communications du Canada.

TECVISION Series v 3.1X

1.0 INTRODUCTION TEC SERIES

The TVHF-50, through TVHF-2000 for hands free units, and TVSH-50, through TVSH-2000 for hand set units, are automatic call and entry control systems utilizing a large screen display .

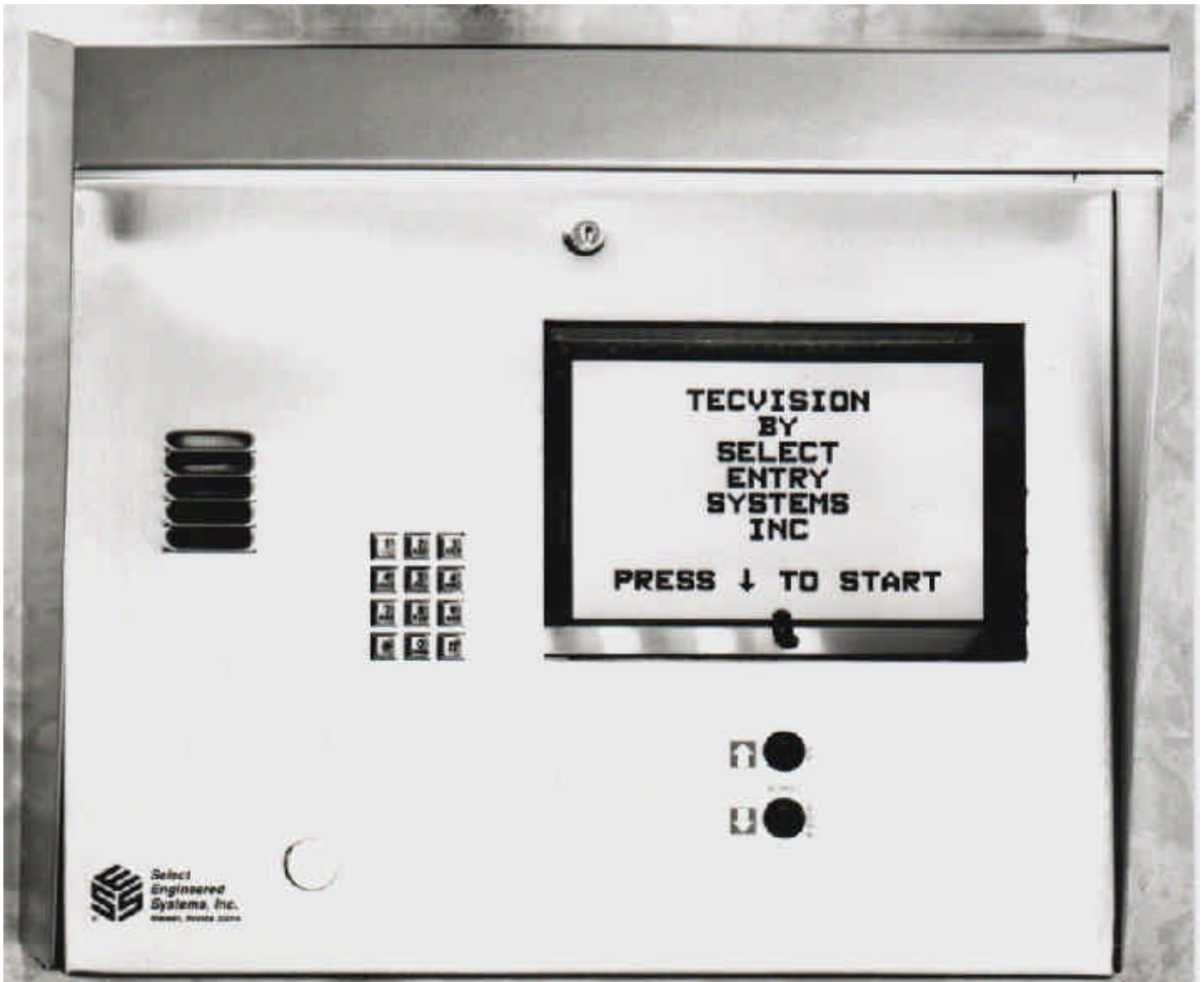

1.1 STANDARD FEATURES:

- M Memory Capacity:
50/75/100/150/250/500/750/1000/2000 for residents telephone numbers and names in directory.
- M Dials out either Touch-Tone™ or rotary - field programmable.
- M Dials up to 14 digit phone numbers.
- M Unit will mute tones in speaker during dialing.
- M Unit will not accept Touch-Tone™ signals through the microphone.
- M Programmable without opening cabinet, via keypad, RS-232, or modem with Selcom 95
- M Talk time field programmable from 1 - 99 min.
- M Postal lock capability included.
- M Request to exit input for all entrance control relays.
- M Entry code attempts (strike out) programmable from 0 - 9.
- M Non-volatile memory.
- M Surface or semi-flush mounting.
- M Remote relay activation.
- M Latching relays (with Remote Control Password).
- M Programmable background "beep" to indicate call placed from telephone entry unit.
- M Personal Identification Number (PIN code). Extra PIN codes above unit capacity.
- M Remote Touch-Tone™ Relay Control.
- M Manager Password (First three digits of Program Password).
- M Battery charging circuitry.

1.2 STANDARD SPECIAL FEATURES

- M 1 - 6 digit directory codes field programmable.
- M 0 - 6 digit entry codes Personal Identification Number (PIN) field programmable.
- M Resident activated door/gate release via Touch-Tone™ number (1-9), field programmable.
- M Voice mail response capability. (Keypad active after unit calls out, programmed from TEC).
- M Crystal controlled tone detection for short burst 50 MS tone.
- M Speaker Listen-in.
- Ž Hide Name Feature. Allows people to dial a code without displaying name on directory.
- M Two minute modem lockout time.

1.3 OPTIONS:

M Card reader control module for 2 doors using these technologies:

! Wiegand, swipe, insert, or keypad.

! Barium Ferrite, Proximity, RF Transmitter, Mag stripe (Wiegand code only), Long Range Proximity.

M Clock & Calendar, timed lock and unlock.

M Time Zones, Access Levels, and Holidays.

M Printer capability (RS-232 port) or Current Loop to printer

(Baud rates to printer and/or remote terminal (CRT)) 300, 600, 1200, 2400, 4800, 9600, 19200

M Third signal relay with two modes of operation:

1) for CCTV activation, alarm output, tamper input)

2) or for control of a third door (timed and latched functions).

M Multiple TEC's (4 - 8 depending on programming mode) can share same telephone line, via multiple unit interfaces (OPTKMUI).

M Ground start.

M Local ringer capability.

M Standby batteries.

M Transaction Buffer (up to 10,000 transactions depending on code size and options).

M 300 - 1200, or 300 - 9600 Baud modem.

BASIC OPERATION:

The TEC is a microprocessor based device that allows entering from 1 - 6 digits on the front keypad. It then automatically dials the phone number programmed into memory. The TEC provides a relay output for controlling doors, gates, elevators or any device actuated by a contact closure or contact opening. The TEC has a programmable 1 to 99 minute talk-time limit. It provides warning tones near the end of talk time.

To operate the TEC, press the "\" key under the display to reach the desired name. If you skip past the desired name, press the "[" key to scroll back to the desired name. After locating the name push the code number on the keypad corresponding to that name. The TEC will automatically dial that number.

Personal Identification Numbers (PINs) are available. Entering a r, then a valid PIN code will energize the main control relay.

The TEC will dial out either pulse (rotary) or Touch-Tone™ via programming selection. While the TEC dials, the speaker disconnects, keeping the dialed phone number confidential.

The TEC has an (optional) alarm output relay (OPTK3R). This can be used with a door ajar input for different entrance control requirements. It also can be re-configured for a third door control.

Calling the TEC from a Touch-Tone™ telephone will allow the user to control the output relays. When the user calls the TEC, the TEC will ring, go off hook and send a ¼ second tone. Entering the proper control password will allow access to the output relays. This also allows relay latching functions.

The (Optional) 12 volt DC .8 A/hr internal battery (B12V) is recommended for line stability. The battery is NOT required for memory storage. SES supplies the TEC with a 18 vac transformer that will operate the TEC and recharge the optional internal battery.

DO NOT CONNECT ANY OTHER DEVICES TO THE BATTERY.

1.4 ENVIRONMENTAL CONSIDERATIONS

Indoor or Outdoor: The standard TEC housing is suitable for indoor or outdoor installations. For semi-flush installations, contact SES about the optional flush ring (OPTFLR). For surface mount installations, contact SES for the optional trim ring (OPTSL-2). Optional pedestal mounts for curb (PST236), or street (PST242).

Dimensions: TEC largest outside dimensions are (approx.) 21" W X 16" H X 6" D.

1.5 ELECTRICAL REQUIREMENTS

Power: The TEC uses 18 volt ac 50/60 Hz. SES supplies a 18 vac transformer with each purchase in the U.S. only. The installer may choose to provide their own 12 volt 300-600 ma. DC supply (for TEC only depending on model type, will not also power card readers). **YOU CAN NOT USE AC TRANSFORMER AND DC SUPPLY AT THE SAME TIME.**

Ground: The TEC must be connected to a good earth ground with at least # 16 ga. stranded wire. This wire **MUST** be a minimum of 16 ga. connected to a ground rod or cold water pipe at one end, and to the provided ¼ -20 bolt at the TEC end.. The maximum wire length is 50 feet. Surge damage protection built into TEC diminishes if you do not provide an adequate earth ground.

Relay capabilities: 50 volts AC or DC at 3 amp. Form "A" (N/O) or form "B" (N/C) contacts are selectable for all relays. These are jumper selected (see Pg. 9 to set relay jumpers).

Gate controllers: Some solid-state gate controllers react to the over-voltage protection devices used on all SES products. This is a gate controller dependent problem. The symptom is an intermittent gate open, or gate stuck open condition, sometimes occurring after using the latching function. If this occurs, add an external relay controlled by the TEC output relay contacts to your gate system (OPTKFRMC) . This will help isolate the contacts going to your solid state gate controller from the over-voltage protection devices.

Pedestal Mounting: For installations where the TEC will be mounted on a pedestal, a ground rod **MUST** be installed immediately adjacent to the TEC. In addition, a ground wire of at least # 14 gauge wire must be used from the ¼-20 ground lug mounted in the back of the TEC back-box to the ground rod clamp. This ground wire is to be no more than 25 feet in length, and should have no sharp bends in the wiring.

1.6 TECHNICAL DATA

M POWER INPUT: 18 VAC 50 VA UL LISTED TRANSFORMER (PROVIDED).

M EMERGENCY BATTERY: 12V .8 A/HR GEL CELL ON CONSTANT CHARGE (OPTIONAL).

M TELEPHONE LINE: VOICE GRADE RJ-11C JACK.

M SHIPPING WEIGHT: APPROXIMATELY 33 LBS.

M CONSTRUCTION: FRONT PANEL: 16 GA. STAINLESS STEEL
BACK BOX: PAINTED CHEMICALLY TREATED ALLOY ALUMINUM.

M OPERATING ENVIRONMENT: TEMPERATURE: -20E F TO +158E F.
RELATIVE HUMIDITY: 5% - 95% NON-CONDENSING.

M RELAY OUTPUT: FORM A OR FORM B DRY CONTACT 50V @ 3 AMP.

TECVISION Series v 3.1X

M MOUNTING: SURFACE OR SEMI-FLUSH.

M MEMORY TYPE: NON-VOLATILE.

M TONE DETECTION: CRYSTAL CONTROLLED, WILL DETECT SHORT BURST 50 MILLISECOND TONE.

2.0 INSTALLATION INSTRUCTIONS

NOTE THE FOLLOWING BEFORE ATTEMPTING ANY INSTALLATION:

- A. Never install telephone wiring during a lightning storm.
- B. Never install telephone jacks in wet locations unless the jack is specifically designed for wet locations.
- C. Never touch un-insulated telephone wires or terminals unless the telephone line has been disconnected at the network interface.
- D. Use caution when installing or modifying telephone lines. Installation of TEC requires coordination with your telephone company. SES recommends that a Touch-Tone™ line be installed to allow much faster dialing. If a Touch-Tone™ line is not available, the TEC can be reprogrammed to dial out pulse (rotary) signals.

The phone company may require the following information:

The ringer equivalence number.

The FCC registration number.

These numbers are on the label on the inside door of the TEC.

The desired location of the telephone jack must be given to the phone company at the time you order the phone line.

2.1 INSTALLATION PROCEDURE

- 1) The TEC should be mounted approximately 52 inches above finished floor to the center of the TEC. For drive up applications, TEC should be mounted approximately 42" - 48" above finished flooring to the center of TEC. Hand set units should be mounted 40" - 46" above finished floor to help comply with the Americans with Disabilities Act (ADA).
- 2) To surface mount the TEC, mount the back-box using the holes provided.
- 3) To flush mount the TEC, cut a hole the size of the back box (21" wide X 16" high) in the wall. Mount the TEC in the hole.
- 4) The TEC MUST BE AT EARTH GROUND POTENTIAL. Connect a #16 stranded or larger wire from the ground lug mounted on the back-box of the TEC (See section 3.1 Connections, on Pg. 8) to a cold water pipe or other suitable ground. This wire should be less than 50 feet in length.
- 5) Connect the wires for the power connections to TBS-5 and TBS-6, as shown on Pg. 8. Connect the other ends of the wires to the screws on the supplied transformer (18 vac 40 va). Plug the transformer into a 110vac outlet.

Recommended wire gauge is as shown: 14 ga. up to 50 feet.
12 ga. up to 100 feet.
10 ga. up to 200 feet.

For unusual distances or requirements please consult factory.

6) If you are using the N.O. contacts on the entrance 1 relay, connect the wires from the controlled device to TBS-13 and TBS-14, as shown on Pg. 8. To use the N.C. contacts, change the relay jumpers (as shown on Pg. 9), and connect the wires from the controlled device to TBS-13 and TBS-14. If a Form C connection is required, purchase the Optional Form C relay adapter (OPTKFRMC). Wire entrance 2 relay to TBS-15 and TBS-16 in the same manner/

NOTE: THE RELAY CONTACTS ARE RATED FOR 50 VOLTS AC OR DC AT 3 AMPS MAXIMUM.

7) Connect the modular plug for the telephone line to the RJ-11 jack provided by the phone company. No other telephones or equipment should be on this line. If attaching multiple TEC's to a single phone line, the optional OPTKMUUI (Multiple Unit Interface) may be purchased. For further information, see Section 10 on Page 47.

8) All wire openings, or any penetration of the TEC enclosure should be sealed with a good grade of RTV silicon sealant.

9) This completes the installation.

3.0 WIRING HOOKUP CONNECTIONS

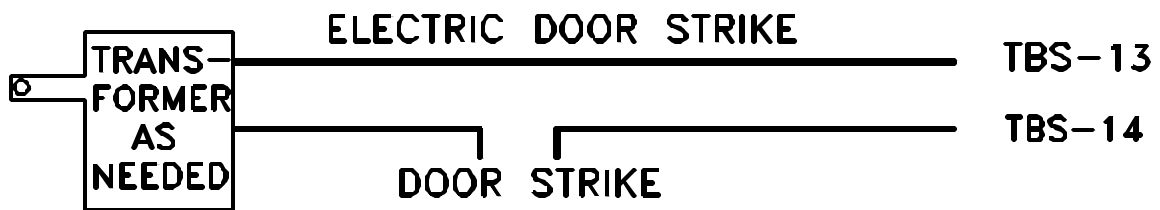
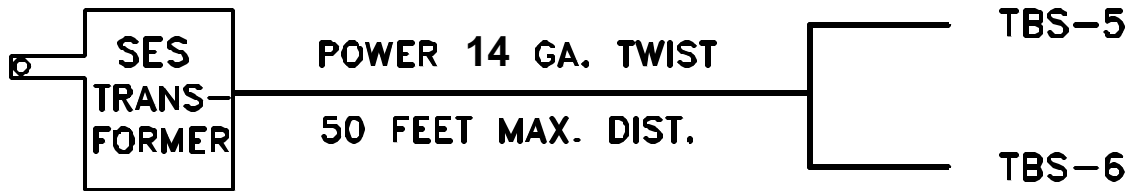
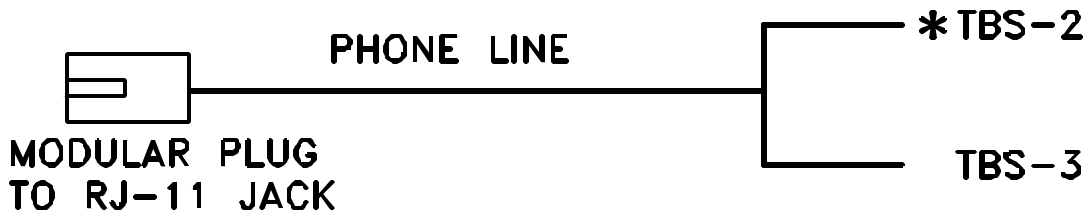

TO SET JUMPERS FOR N/C OR N/O SEE PG. 9

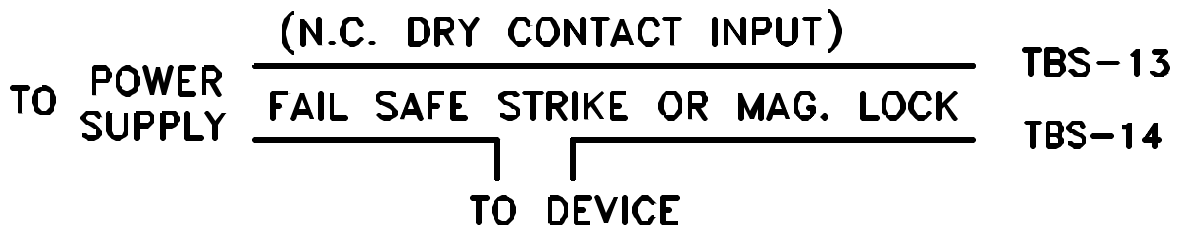

* TBS = TERMINAL BARRIER STRIP ON SIDE OF HOUSING

3.1 TERMINAL BARRIER STRIP CONNECTIONS

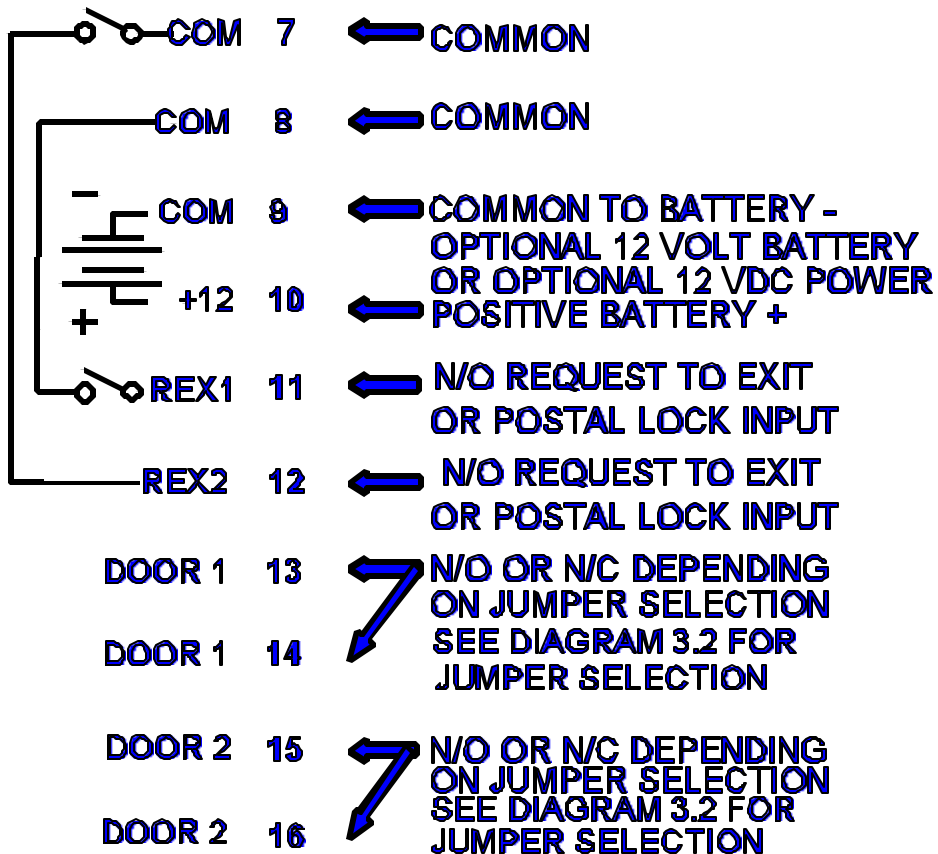
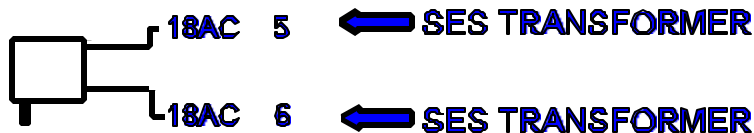
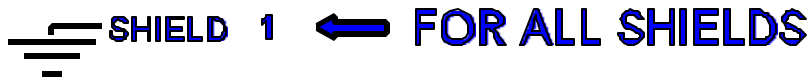
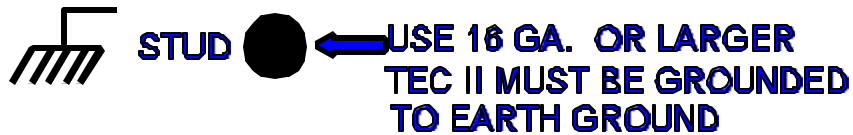

3.2 RELAY JUMPER SELECTION

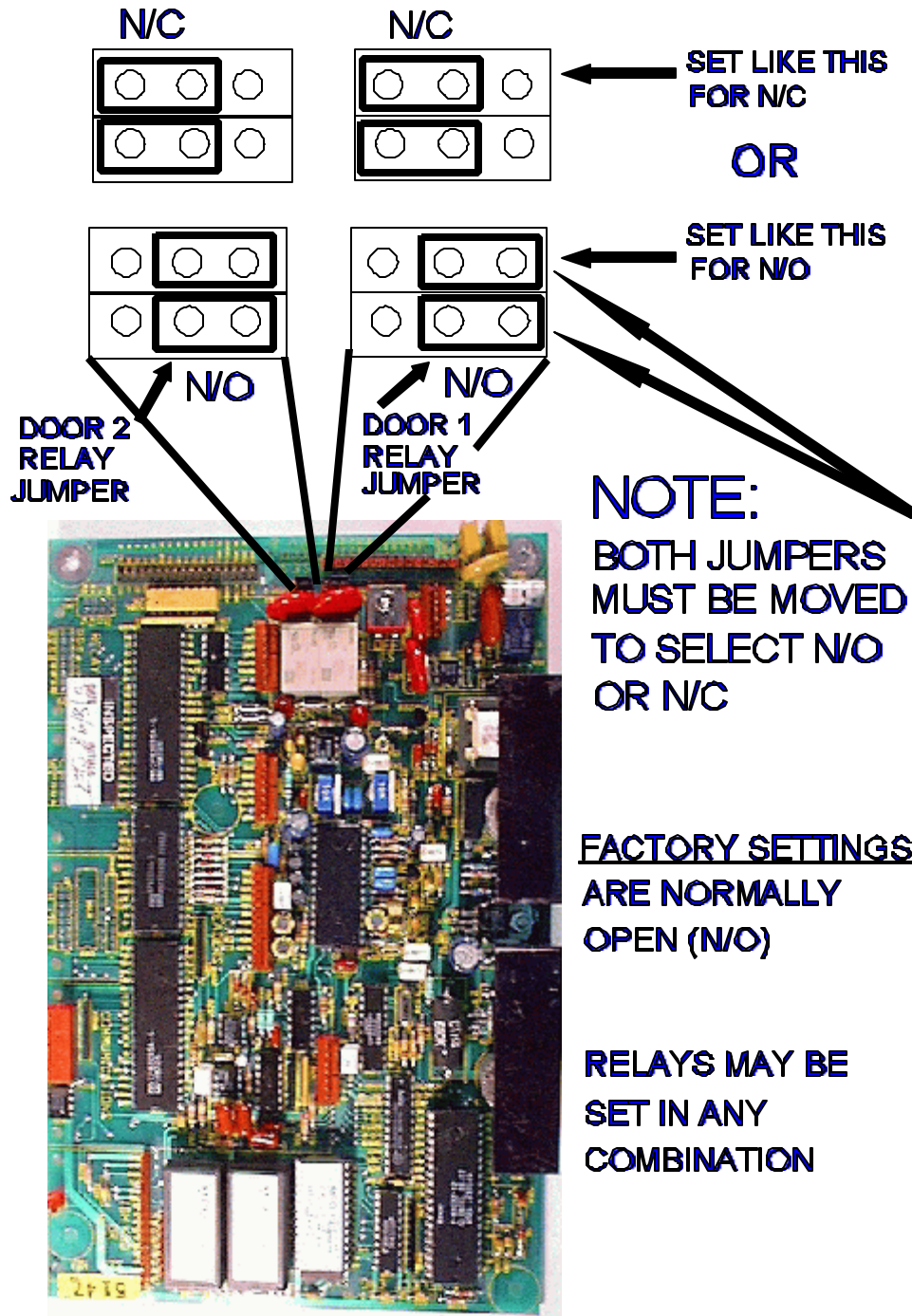

Diagram 3.2

4.0 SETUP AND PROGRAMMING

Setup refers to configuration of a TEC, usually during installation. This may include how long the door entry time is, or what number energizes the door control relay. Any options such as card readers or automatic unlock and re-lock, are configured at this time. The installer of the TEC generally performs these tasks.

Programming refers to the entry of codes, names, phone numbers, and PINs (Personal Identification Numbers). The end user or customer generally enters the data, and periodically updates it as required.

If the factory defaults shown on Pg. 13 and 14 are adequate for an installation, then the following "Quick Programming" section will give an example of a typical code entry. No explanations about menu selection function will be provided. SES strongly recommends that installers without previous experience in telephone entry control systems read this manual in its entirety.

4.0.1 QUICK PROGRAMMING EXAMPLE

This example assumes all factory defaults, including factory default passcode 777777 are in the TEC and you have entered no other data. This benefits those with experience installing and programming telephone entry systems.

This example enters the following data into the TEC from the keypad on the TEC front door:

CODE:	NAME:	PHONE:	PIN:
001	SMITH,FRED	555-1234	1234
123	DOE,JOHN	555-9876	5678

1. To begin programming press the "r" and the "0" keys simultaneously.
2. Enter passcode number 777777.
3. Press r.
4. Press 1.
5. Press 1.
6. Press 001r.
7. Press 777#6#444#8#44#1111#333#77#33#3#r 5551234r 1234r.
8. Press 123 r.
9. Press 3#666#33#1111#5#666#44#66#r 5559876r 5678r.
10. Press the "r" and the "0" keys simultaneously.

Press the # key twice. You should see both codes and names in the display (one after the other). If you had any problems entering the data, or if you did not understand the reason for a key entry, please read the rest of this manual.

4.1 SETUP

After the TEC first powers on, the message "PRESS \ TO START" will appear in the LCD display. The contrast control on the LCD board may have to be adjusted for best contrast, depending on lighting conditions. This adjustment is on the inside door near the top of the door, above the keypad. See the diagram below.

Optional IBM keyboard

Adjust contrast as required.

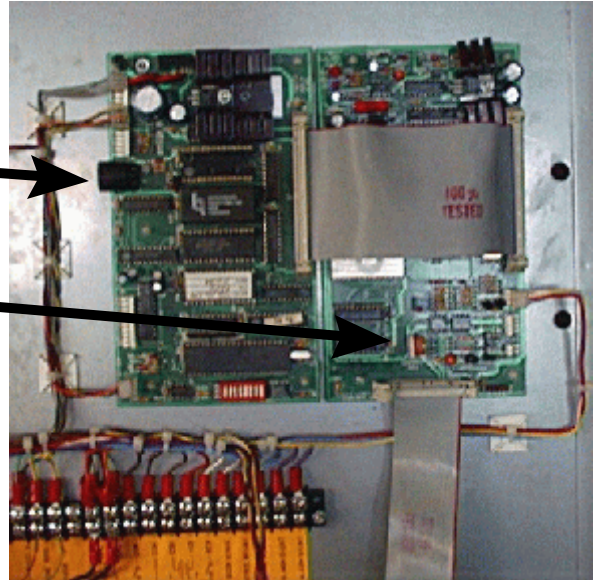

To begin programming press the "r" and the "0" keys simultaneously

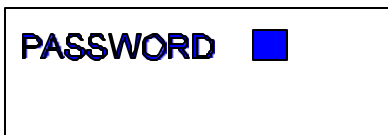

¶ This shows on the display window



After you see this in the window, you have six seconds to start to press the six digit pass code. The factory default pass code is 777777. Each time you press a key, a "r" will appear in the window to keep the pass code confidential. After entering the sixth key, press the "r" key. This should bring you to the main menu. If you don't press a key in any 6 second period, the TEC automatically reverts to operational mode. If during programming, you don't press any key for 60 seconds, the TEC automatically reverts to operational mode.

The choices for the main menu are:

1. CODES / NAMES
2. ENT. CONTROL
3. SYSTEM PARAMETERS
4. COMMUNICATIONS SETUP
5. CLOCK SETUP
6. ACCESS CONTROL

8. CLEAR DATA
9. DISPLAY DATA

7. BUFFER INFO

The nine choices above may have from 1 to 9 additional choices in a particular category. After you make a menu selection, pressing a "r" will return to the main menu.

The black box represents the cursor. It shows where to expect the next character. In the remaining examples of this manual, there are text examples where the cursor is assumed. We will not show the keypad for the remaining examples, key inputs will be referred to directly in the text.

The "#" key has different functions when in different sub-menus or different programming modes. Usually, the "#" key will advance the cursor one space to the right. Most functions require the "#" key to shift a character to the right to make a selection or function valid.

The "r" key acts similar to a \backslash or carriage return key also called the Enter key on a typewriter or a personal computer. If you are using a terminal or computer to program the TEC, press the Enter key or \backslash (carriage return) key whenever the text prompts you for a "r"

The "r" and "0" pressed simultaneously act similar to the "ESC" key on a computer. If you are using a terminal or computer to program the TEC, press the "ESC" key whenever the text prompts you for a "r" and "0".

The "#" and "0" pressed simultaneously act similar to the backspace key on a computer. If you are using a terminal or computer to program the TEC, press the back arrow (\leftarrow) key whenever the text prompts you for a "#" and "0".

4.1.1 MANAGER PASSCODE

The first 3 digits of the 6 digit pass code are for programming main menu choice 1 (CODES/NAMES) only. This is useful for on site maintenance of names and codes. This prevents the system parameters and configuration from being inadvertently modified after installation.

On the following two pages is an overview of the menu selections possible on a TEC.

NOTE: () REFERS TO SECTION IN MANUAL DESCRIBING FUNCTION

MAIN MENU	SECTION	FOLLOW MENU	FACTORY DEFAULTS
1 = CODES / NAMES			
1 = ADD / FIND NAME	(4.2.1)		
2 = FIND NAME	(4.2.1.1)		
3 = FIND PIN	(4.2.1.2)		
4 = FIND CARD	(4.2.1.3)		
5 = CODES USED	(4.2.1.4)		
6 = SHOW ALL CODES	(4.2.1.5)		
7 = SHOW ALL NAMES	(4.2.1.8)		
8 = ENA ACC GRP	(4.2.1.9)		
2 = ENT. CONTROL	(4.2.1.10)		
1 = ENT 1 CONFIG	(4.2.2)		
1 = UNLOCK TIME	(4.2.2.1)	1 - 99 SECONDS	10
2 = UNLOCK TONE	(4.2.2.2)	0 - 9 T-TONE RECVD	6
3 = AUTO GROUP	(4.2.2.3)	0 - 7	0
4 = LATCH TONE	(4.2.2.4)	0 - 9 T-TONE RECVD	0
5 = AJAR TIME	(4.2.2.5)	0 - 99 SECONDS	20
2 = ENT 2 CONFIG			
1 = UNLOCK TIME	(4.2.2.6)	1 - 99 SECONDS	10
2 = UNLOCK TONE	(4.2.2.7)	0 - 9 T-TONE RECVD	0
3 = AUTO GROUP	(4.2.2.8)	0 - 7	0
4 = LATCH TONE	(4.2.2.9)	0 - 9 T-TONE RECVD	0
5 = AJAR TIME	(4.2.2.10)	0 - 99 SECONDS	20
3 = SYS. PARAMETERS	(4.2.3)		
1 = TALK TIME	(4.2.3.1)	1 - 99 MINUTES	01
2 = ALARM TIME	(4.2.3.2)	1 - 99 SECONDS	10
3 = CODE LENGTH	(4.2.3.3)	1 - 6 DIR LENGTH	3
4 = PIN LENGTH	(4.2.3.4)	0 - 6 PIN LENGTH	4
5 = BACK BEEP	(4.2.3.5)	0-1, (1 = ENABLE)	0
6 = TONE DIAL	(4.2.3.6)	0-1, (1 = T-TONE DIAL)	1
7 = RING COUNT	(4.2.3.7)	0 - 9 RING COUNT	3
8 = STRIKE OUT	(4.2.3.8)	0-1, (1 = ENABLE)	0
9 = TITLE PAGE	(4.2.3.9)		

4.2 PROGRAMMING CHOICES

FACTORY DEFAULT

0 - 1, (1 = VT100A) 1
 0 - 6, (0=300, 6=19200) 5
 1 - 6 DIGITS 777777
 1 DIGIT 1
 0 - 255 0000
 0 - 1, (1 = ON) 221000
 0 - 9 00

PROGRAMMING CHOICES

- 4 = COMM. SETUP**
- 1 = TERMINAL TYPE (4.2.4)
- 2 = RS-232 BAUD (4.2.4.1)
- 3 = PROGRAM PASSWORD (4.2.4.2)
- 4 = PIN ON ENT (4.2.4.3)
- 5 = SITE CODE (4.2.4.4)
- 6 = TV LCD CONFIG (4.2.4.5)
- 7 = KEYPAD ON / OFF (4.2.4.6)
- 8 = SPEAKER TONE (4.2.4.7)
- 9 = UPDATE LCD (4.2.4.8)
- (4.2.4.9)

- 5 = CLOCK SETUP**
- 1 = SET CLOCK (4.2.5)
- 2 = SET TIME ZONES (4.2.5.1)
- 3 = SET HOLIDAYS (4.2.5.2)
- (4.2.5.3)

- 6 = ACCESS CONTROL**
- 1 = SET GROUPS (4.2.6)
- 2 = SET LEVELS (4.2.6.1)
- (4.2.6.2)

- 7 = BUFFER INFORMATION**
- 1 = VIEW LOG (4.2.7)
- 2 = SEND LOG (4.2.7.1)
- 3 = FIND CODE (4.2.7.2)
- 4 = LOG SIZE (4.2.7.3)
- 5 = CLEAR BUFFER (4.2.7.4)
- (4.2.7.5)

- 8 = CLEAR DATA**
- 1 = SET PARAMETERS (4.2.8)
- 2 = CLEAR TIME ZONES (4.2.8.1)
- 3 = CLEAR HOLIDAYS (4.2.8.2)
- 4 = CLEAR AC-LEVELS (4.2.8.3)
- 5 = CLEAR AC-GROUPS (4.2.8.4)
- 6 = CLEAN CODES (4.2.8.5)
- (4.2.8.6)

- 9 = DISPLAY DATA**
- 1 = PRINT INFO (4.2.9)
- 2 = PRINT TIME ZONES (4.2.9.1)
- 3 = PRINT HOLIDAYS (4.2.9.2)
- 4 = PRINT A-C LEVELS (4.2.9.3)
- 5 = PRINT A-C GROUPS (4.2.9.4)
- (4.2.9.5)

4.2.1 CODES / NAMES

**CODES/NAMES
SELECT 1 - 7**

Pressing "1" (after entering the password) will show the choice at left.

A CODE refers to a record in the Tec's memory. A record consists of:

CODE#	NAME	PHONE	PIN	CARD	ACCESS	GROUP
-------	------	-------	-----	------	--------	-------

123	JONES, TIM	555-1212		1234	2760	1
-----	------------	----------	--	------	------	---

- A. Code numbers can be from 1 to 6 digits.
- B. Names and phone numbers must be entered to display name on directory
- C. Phone numbers can be entered without name, but will not display on directory.
- D. PIN (Personal Identification Number) codes are associated with code numbers.
- E. Optional card numbers (for systems so equipped) are associated with code numbers.
- F. Access Groups are associated with code numbers.

4.2.1.1 ADD / FIND NAME

CODE =

Press "1" on the Codes/Names menu. You will be prompted for the code as shown at left:

If you make a mistake while keying in the code number, press the "0" and the "#" simultaneously to move back one space. From a terminal or computer, press the back arrow key. Enter the code number. It will be between one and six digits depending on the system parameters (see section 4.2.3). After keying in the desired code number, press the "r".

From a terminal or computer, press the "Enter" or 5 key.

4.2.1.1 A DELETING A CODE

To delete a code number, key in the code number then press "#" followed by "r". This also will erase all data associated with that code number, such as the name, phone number, PIN, and card number. From a terminal or computer, press the "DEL" (delete key) followed by the "Enter" or 5 key.

4.2.1.1 B DELETING A CODE FIELD

To delete a part of a code number, such as a phone number, PIN # or card #, go to that field by pressing the "r" key. When you reach the desired field, key in "0", then "r" from the keypad. This will delete the data in that field, but not any of the other fields associated with the code number. From a terminal or computer, press the "Enter" or 5 key until you reach the desired field. Key in "0", and then the "Enter" or 5 key.

IF YOU PLACE A "0", IN THE FIRST POSITION OF A NAME FIELD, THEN "#", IT WILL DELETE ALL DATA ASSOCIATED WITH THAT CODE NUMBER.

FOR CHARACTERS:

NAME =

For TEC models, you will be prompted to enter a name. Names are 1 to 14 characters, including punctuation. The keys on the keypad are alphanumeric. Since there are only 12 keys, each key generates it's number, more than one letter, and punctuation.

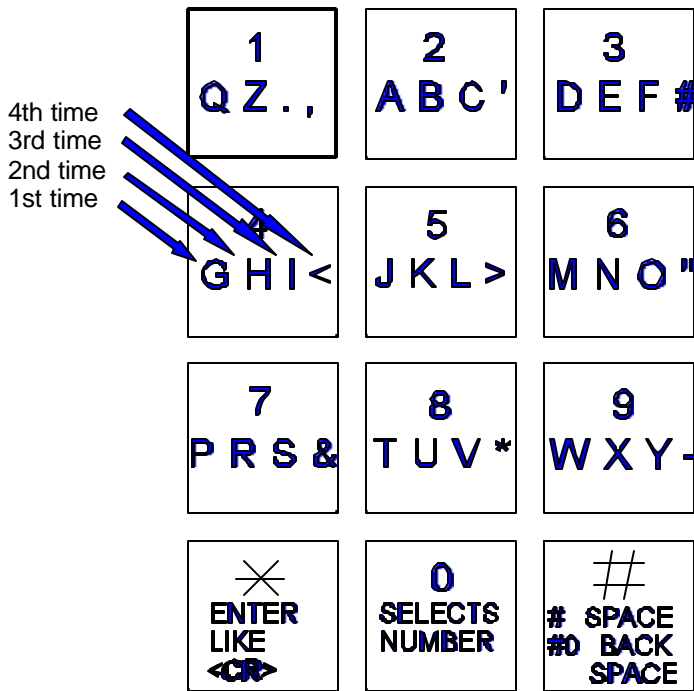

The first time you press a key, the first character corresponding to that key will appear in the display. To get to the second character, press the same key a second time. To get the third character, press the same key a third time. To skip a space, press the "#" key. To backspace, press the "0" and the "#" simultaneously. A backspace over an existing character will delete that character. If you inadvertently key past the desired character, keep pressing the key until the desired character is in the window. Then press the "#" key to advance to the next space.

FOR NUMBERS:

To select numbers, press the "0" key and then the desired number key.

After completely entering the name, press the "r" key to enter the name into memory.

NOTE: PRESS THE # KEY TO MOVE PAST THE LAST LETTER BEFORE PRESSING r, OR LAST LETTER IS NOT PROGRAMMED.

PHONE # =

You will be prompted for the phone number. Enter the numbers normally. In this mode, letters are not possible. If you mis-key a digit of the phone number, press the "0" and the "#" simultaneously to backspace and correct the digit. After completely entering the phone number, press the "r" key to enter the phone number into memory. To create a 3 second pause, press the "#" key. For phone systems that dial an 8 or a 9 to get an outside line, key in the number then the "#", then the phone number, then "r". From a computer or terminal, press the ":" key to generate a 3 second pause.

HIDE NAME FEATURE: Place a pause as the first item in the phone number (ex. #5551212). The name will not display in the directory, but anyone who dials the code number will still be able to reach the resident.

PIN =

You will be prompted to enter a PIN. A PIN is a Personal Identification Number. This will allow anyone who knows this number to enter the facility the TEC controls by entering a "r" and this PIN code. Each name may have a PIN code. The PIN code length is from one to six digits, depending on what you selected from the system parameters menu (see section 4.2.3.4). All PIN codes must be the

TECVISION Series v 3.1X

same length as what was selected from the system parameters menu. When you enter the PIN code, press the "r" key to place the PIN code into memory. If you disable the PIN (PIN length = 0), this choice will not display.

Another selection in this sub-menu is the card reader number. This is a five digit number used with the optional card reader interface. If you do not have a card reader interface option, or if Facility Site code = 000, this selection may not display.

The card number for the card that will be given to the resident for this name must be known. Enter this number into memory. If you make mistakes while keying in the number, press the "0" and the "#" key pressed simultaneously. From a terminal, press the back arrow. This will backspace over the mis-keyed digit. After entering the Card code number, press the "r" key to place the Card code number into memory.

CARD =

If you have enabled Access Groups, (4.2.3.8) any one of the 8 Access Groups (0 - 7) may be chosen. If they have not been enabled, or if Access Group = 0, this menu choice will not display.

SET ACC GRP =

4.2.1.2 FIND NAME

To select the find name function, press "2" from the Codes/Names menu. You will be prompted for 1 - 6 characters. Select characters in the same manner that you programmed names into memory (See the diagram on Pg. 16). When you have entered all desired characters, press "#", then "r"

1-6 CHAR. <CR>

This message will display whatever code number matches the letters selected. If there is more than one name with similar letters, pressing the "r" key will display additional code numbers that meet the selection criteria.

**CODE = XXX
<CR>MORE**

If there is no match, you will be prompted to press either the "r" from the keypad, or Enter key from the terminal. A <CR> or "r" will return to sub-menu 1 (See section 4.2.1 Codes / Names).

**NO MATCH
<r> TO CONT**

4.2.1.3 FIND PIN

To find a PIN code press "3" from the Codes/Names menu. Next, enter the PIN code, followed by pressing "r".

FIND PIN

Assuming you had assigned 1234 to code # 001, the window would look like the one at right. Pressing a "r" will return to the "Find Pin" sub-menu.

**FIND PIN 1234
CODE PIN 001234
NOT FOUND**

If a PIN code # is not in memory, the "Not Found" sub-menu will display as shown. In this example, 234 was entered. Since the PIN codes have been defined as 4 digits, the TEC supplied a leading "0" and displayed the "NOT FOUND" message.

4.2.1.4 FIND CARD

FIND CARD

This menu selection is only for system installations that also make use of the optional card reader. Select this sub-menu from the Codes/Names menu by pressing "4". The display will show "Find Card". Enter the card number and press "r".

**FIND CARD =
00456**

If the card number has been assigned, the code number associated with that card number will display as shown at left.

**FIND CARD=00456
NOT FOUND**

If the card number has not been assigned, then the error message at left, will be displayed. Press "r" and another number to find another card number, or press "r" again and return to the Codes/Names sub-menu.

4.2.1.5 CODES USED

**CODES USED 0021
PH # USED 0021**

The codes used sub-menu is reached by pressing "5" on the Codes/Names menu. The number of codes used and the number of phone numbers used will be displayed as shown at left.

4.2.1.6 SHOW ALL CODES

Select this sub-menu from the Codes/Names menu by pressing "6". This selection will list code numbers and all data associated with code numbers, sorted by CODE NUMBER in ascending order. It sends this data out the optional serial port (OPTKPRT) to a printer or terminal. If you are using the optional modem with a personal computer it will send the data to the computer screen.

4.2.1.7 SHOW ALL NAMES

Select this sub-menu from the Codes/Names menu by pressing "7". This selection will list code numbers and all data associated with code numbers, sorted by NAMES in ascending order. It sends this data out the optional serial port (OPTKPRT) to a printer or terminal. If you are using the optional modem with a personal computer it will send the data to the computer screen.

ENA ACC GRP = 0

4.2.1.8 ENABLE ACCESS GROUPS

Access Groups allow more control of a TEC by adding time zone control and increased card reader control.

TECVISION Series v 3.1X

To enable Access Groups from the factory default of 0, press "8" from the Codes / Names menu to get this sub-menu. Press "1" to enable Access Groups, and press "r". This will return you to the Codes / Names menu.

4.2.2 ENTRY CONTROL

The Entry Control menu comes with factory defaults that should be sufficient for most installations. These default values are shown on Pg. 13 and 14 (see section 4.2.2). Some functions work with options that may not be present on your TEC. To get the menu at right, press "2" and then "1" from the main menu.

**ENT 1
SEL FUNCT 1 - 5**

4.2.2.1 ENTRANCE 1 UNLOCK TIME

Press "1" from the Entry Control menu to set the time in seconds from 1 to 99 seconds. This is the length of time the door control relay for door 1 will be energized. The factory default is 10 seconds. A good rule of thumb for entry time is 3 seconds plus 2 seconds for every step from the TEC to the entrance being controlled. To change time, key in the time desired and press the "r" key. You will be returned to the Entry Control menu.

**ENT 1
UNLOCK TIME = 10**

4.2.2.2 ENTRANCE 1 UNLOCK TONE

The Entrance 1 tone refers to the Touch-Tone™ number from a telephone that must be pressed to energize the door control relay. This relay will be energized for whatever length of time was selected (see section 4.2.2.1; door open time). Rotary or pulse type telephones must dial any number "6" or greater to energize the door control relay. This will energize only the primary door control relay. To change the number from the default setting of 6 to another number, press "2" from the Entrance 1 Control menu. Select the new number (from 1 -9) and press the "r" key. You will be returned to the Entry Control menu.

**ENT 1
UNLOCK TONE = 6**

SELECTING A "0" DISABLES ENTRANCE 1 UNLOCK TONE FEATURE.

4.2.2.3 ENTRANCE 1 AUTO GROUP

The Entrance 1 Auto Group refers to the group of Access levels and time zones that allow the entrance to automatically open on given days for the hours that match the time zone programmed. . To change the number from the default setting of 0 to another number, press "3" from the ENT 1 Control menu. Select the new number (from 0 - 7) and press the "r" key. You will be returned to the Entry Control menu. **SELECTING A "0" DISABLES THE AUTO GROUP FUNCTION.** Selecting a number from 1 - 7 allows that number to automatically open the door on the days and times set for that group.

**ENT 1
AUTO GROUP = 0**

NOTE: AUTOMATIC UNLOCK/RE-LOCK (AUTO GROUP) OVERRIDES ANY OTHER LATCH CONTROL.

4.2.2.4 ENTRANCE 1 LATCH TONE

The ENT 1 latch tone refers to the Touch-Tone™ number from a telephone that must be pressed to energize the entrance control relay. Unlike the Entrance 1 unlock tone that was timed, this relay will be energized (or latched) until called back and unlatched. To unlatch a door that has been latched, use the Entrance 1

**ENT 1
LATCH TONE = 0**

unlock tone, which will relock the door after time out. To change the number from the default setting of 0 to another number, press "4" from the ENT Control menu. Select the new number (from 0 - 9) and press the "r" key. You will be returned to the ENT Control menu. **SELECTING A "0" DISABLES THE LATCHING FUNCTION.** Selecting a number from 1 - 9 allows that number to latch the Entrance 1 relay only when you call the TEC.

NOTE: IF ENT 1 TONE AND ENT 1 LATCH ARE THE SAME NUMBER, THE ENT 1 RELAY WILL NOT LATCH OR TIME OUT. IT WILL ENERGIZE BRIEFLY, AND THEN DE-ENERGIZE.

4.2.2.5 ENTRANCE 1 AJAR TIME

**ENT 1
AJAR TIME = 20**

Press "1" then "5" from the Entry Control menu to set the ajar time in seconds from 1 to 99 seconds. The factory default is 20 seconds. To change time, key in the time desired and press the "r" key. You will be returned to the Entry Control menu. The door ajar timer may be used with a normally open sensor such as a magnetic reed switch connected to the door. Wire this to the door sense input on the OPTK2R module (See Section 12.0 Pg. 48) After the door control relay is energized, opening the door causes a contact closure across the door sense

input. This de-energizes the door control relay (causing a re-lock when the door closes). After door open time out, the ajar timer begins. If the door is not closed before the ajar timer times out, an ajar alarm can occur. Five seconds after the ajar timer times out, the shunt relay on the OPTK2R module will de-energize. If the optional alarm relay (OPTK3R) is installed, it will energize at this time.

Press "r" and "0" simultaneously to escape out of these menus and return the TEC to normal operation, or a "r" to return to the previous menu.

4.2.2.6 ENTRANCE 2 UNLOCK TIME

**ENT 2
UNLOCK TIME = 10**

Press "2" then "1" from the Entry Control menu to set the time in seconds from 1 to 99 seconds. This is the length of time the door control relay for door 1 will be energized. The factory default is 10 seconds. A good rule of thumb for entry time is 3 seconds plus 2 seconds for every step from the TEC to the entrance being controlled. To change time, key in the time desired and press the "r" key. You will be returned to the Entry Control menu.

Press "r" and "0" simultaneously to escape out of these menus and return the TEC to normal operation, or a "r" to return to the previous menu.

4.2.2.7 ENTRANCE 2 UNLOCK TONE

**ENT 2
UNLOCK TONE = 0**

The Entrance 2 tone refers to the Touch-Tone™ number from a telephone that must be pressed to energize the door control relay. This relay will be energized for whatever length of time was selected (see section 4.2.2.6; door open time). To change the number from the default setting of 0 (disabled) to another number, press "2" from the Entry 2 Control menu. Select the new number (from 1 - 9) and press the "r" key. You will be returned to the Entrance Control menu.

SELECTING A "0" DISABLES ENTRANCE 2 UNLOCK TONE FEATURE.

4.2.2.8 ENTRANCE 2 AUTO GROUP

**ENT 2
AUTO GROUP = 0**

The Entrance 2 Auto Group refers to the group of Access levels and time zones that allow the entrance to automatically open on given days for the hours that match the time zone programmed. . To change the number from the default setting of 0 to another number, press "3" from the ENT 2 Control menu. Select the new number (from 0 - 7) and press the "r" key. You will be returned to the Entry Control menu. **SELECTING A "0" DISABLES THE ENTRANCE 2 AUTO GROUP FUNCTION.** Selecting a number from 1 - 7 allows that number to automatically

open the door on the days and times set for that group.

NOTE: AUTOMATIC UNLOCK/RE-LOCK (AUTO GROUP) OVERRIDES ANY OTHER LATCH CONTROL.

4.2.2.9 ENTRANCE 2 LATCH TONE

The ENT 2 latch tone refers to the Touch-Tone™ number from a telephone that must be pressed to energize the entrance control relay. Unlike the Entrance 2 unlock tone that was timed, this relay will be energized (or latched) until called back and unlatched. To unlatch a door that has been latched, use the Entrance 2 unlock tone, which will re-lock the door after time out. To change the number from the default setting of 0 to another number, press "4" from the ENT Control menu. Select the new number (from 0 - 9) and press the "r" key. You will be returned to the ENT Control menu. **SELECTING A "0" DISABLES THE LATCHING FUNCTION.** Selecting a number from 1 - 9 allows that number to latch the Entrance 2 relay only when you call the TEC.

**ENT 2
LATCH TONE = 0**

NOTE: IF ENT 2 TONE AND ENT 2 LATCH ARE THE SAME NUMBER, THE ENT 2 RELAY WILL NOT LATCH OR TIME OUT. IT WILL ENERGIZE BRIEFLY, AND THEN DE-ENERGIZE.

4.2.2.10 ENTRANCE 2 AJAR TIME

Press "2" then "5" from the Entry Control menu to set the ajar time in seconds from 1 to 99 seconds. The factory default is 20 seconds. To change time, key in the time desired and press the "r" key. You will be returned to the Entry Control menu. The door ajar timer may be used with a normally open sensor such as a magnetic reed switch connected to the door. Wire this to the door sense input on the OPTK2R module (See section 12.0 Pg. 48) After the door control relay is energized, opening the door causes a contact closure across the door sense input. This de-energizes the door control relay (causing a re-lock when the door closes). After door open time out, the ajar timer begins. If the door is not closed before the ajar timer times out, an ajar alarm can occur. Five seconds after the ajar timer times out, the shunt relay on the OPTK2R module will de-energize. If the optional alarm relay (OPTK3R) is installed, it will energize at this time.

**ENT 2
AJAR TIME = 20**

Press "r" and "0" simultaneously to escape out of these menus and return the TEC to normal operation, or a "r" to return to the previous menu.

4.2.3 SYSTEM PARAMETERS

The System Parameters menu comes with factory defaults that should be sufficient for most installations. These default values are shown on Pg. 13 and 14 (see section 4.2.3). Some functions work with options that may not be present on your TEC. For example, selection 2 Alarm Time is not valid unless the optional alarm control relay (OPTK3R) has been purchased. To get the menu at right, press "3" from the main menu.

**SYS PARAM.
SELECT 1 - 9
TALK TIME = 01**

4.2.3.1 TALK TIME

Talk Time is the time in minutes from 1 - 99 minutes that the TEC remains

connected after dial out. In areas of the country where rate usage is a concern, the factory default is 1 minute. For other applications, the talk time can be adjusted upward by pressing "1" from the System Parameters menu to get this sub-menu. Key in the desired number (must be 2 digits) and press "r". This will return you to the System Parameters menu.

4.2.3.2 ALARM TIME

Alarm time is the time in seconds that the optional alarm relay control (OPTK3R) is energized. To change the alarm time from the factory default of 10 seconds, press "2" from the System Parameters menu to get this sub-menu. Key in the desired number (must be 2 digits) and press "r". This will return you to the System Parameters menu.

ALARM TIME = 10

4.2.3.3 CODE LENGTH

CODE LENGTH = 3

Code length is the number of digits from 1 to 6 entered on the keypad to dial a phone from the TEC. To change the code length from the factory default of 3 digits, press "3" from the System Parameters menu to get this sub-menu. Key in the desired number from 1 - 6 and press "r". This will return you to the System Parameters menu.

4.2.3.4 PIN LENGTH

PIN LENGTH = 4

PIN length is the number of digits from 0 to 6, entered from the keypad to enter a PIN code from the TEC. To change the PIN length from the factory default of 4 digits, press "4" from the System Parameters menu to get this sub-menu. Key in the desired number from 0 - 6.

SELECTING PIN LENGTH = "0" DISABLES THE PIN FUNCTION. Press "r" to return to the System Parameters menu.

4.2.3.5 BACK BEEP

BACK BEEP = 0

Back Beep is a background tone that will "beep" every 10 seconds when enabled. This allows a called party to determine if someone called from a TEC. To enable the back beep from the factory default of 0, press "5" from the System Parameters menu to get this sub-menu. Press "1" to enable Back Beep, and press "r". This will return you to the System Parameters menu.

4.2.3.6 TONE DIAL

TONE DIAL = 1

Tone dial selects whether the TEC dials out with Touch-Tones™, or uses pulses, like rotary dial phones. In areas of the country where Touch-Tone™ is not available, tone dial may be disabled. To disable the Tone Dial from the factory default of 1, press "6" from the System Parameters menu to get this sub-menu. Press "0" to disable Tone Dial, and press "r". This will return you to the System Parameters menu.

4.2.3.7 RING COUNT

RING COUNT = 3

Ring Count is the number of rings the TEC listens to before it answers. This is useful for operating the door control relay without being called, or for Remote Programming. If ring count is 0, the TEC will not answer at all. To change the ring count from the factory default of 3 rings, press "7" from the System Parameters menu to get this sub-menu. Key in the desired number from 0 - 9 and press "r". This will return you to the System Parameters menu.

4.2.3.8 STRIKE OUT

STRIKE OUT = 3

Strike Out refers to the number of incorrect PIN code entries that can be made before the TEC "locks up". Once the TEC "locks up", it ignores any key entries for 60 seconds. This is to discourage attempts to guess PIN codes. Select Strike Out from the Door Control menu by pressing "9". To change from the factory default setting of 3, press any key from 0 - 9 and then press "r".

NOTE: IF 0 IS SELECTED, THE TEC WILL PERMIT UNLIMITED ATTEMPTS TO GUESS PIN CODES.

If you enter an invalid PIN code, an error message like the one at right, will display. Wait until the title screen (if selected) appears, or until the error message goes away before re-keying the PIN code.

**INVALID PIN
TRY AGAIN**

If the number of strike outs is exceeded, an error tone will sound. A message like the one at right, will be shown on the front display of the TEC.

BUSY PLEASE WAIT

If you enter a valid PIN code, the door control relay will energize and the open message shown at right, will display on the TEC for approximately 2 seconds and then revert back to the title page.

OPEN

4.2.3.9 TITLE PAGE

The Title Page has six lines of up to sixteen characters per line, including punctuation. The Title Page can be programmed from the keypad in the same manner as names were programmed (see section 4.2.1.1). See the table below for character assignments.

The TEC comes with a title page that says "PRESS \ TO START", until the title page is reprogrammed. To program the Title Page from the factory default of "PRESS \ TO START", press "9" from the System Parameters menu to get this sub-menu. Key in the desired character and press "#" to advance to the next character space. Press "#" to advance to a blank space. Press "#" and "0" simultaneously to backspace one character. When the first line is complete, press "r" to advance to the second line.

LINE 1

Continue the 2nd through 6th lines as required. If you require any modifications of any line, then line 1 must be re-entered, along with any of the other lines preceding the line you want to change. After completion, press "r". This will return you to the System Parameters menu.

The Title Page can hold six lines of 20 characters per line if an IBM XT compatible keyboard is plugged into the keyboard adaptor of the SVCPU card. See the diagram on Pg. 11 for keyboard connector location.

LINE 2 - 6

TECVISION Series v 3.1X

Password may be alphanumeric (1 - 6 characters) if programmed from an optional terminal. From the front keypad, only numbers (1 - 6 digits) are supported. This provides an additional level of security if you connect a terminal to a TEC. It is possible to create passwords that can not be accessed from the front keypad. To change the Program Password from the factory default of 777777, press "3" from the Communications Setup menu to get this sub-menu. Key in the desired 6 digits for the new password, and press "r". You will be returned to the Communications Setup menu.

NOTE: 1st 2 DIGITS OF PROGRAM PASSWORD ARE THE CONTROL PASSWORD, FOR REMOTE CONTROL OF TEC UNIT (SUCH AS ENTRANCE LATCH). 1st 3 DIGITS OF PROGRAM PASSWORD ARE THE MANAGERS PASSWORD THAT ALLOWS ONLY CODE, NAME, PHONE, PIN, CARD, AND GROUP CHANGES.

4.2.4.3A CONTROL PASSWORD

The control password allows the TEC to be called from a Touch-Tone™ phone and have it's control relay operated, without having the entire program password compromised. This is the 1st 2 digits of the program password, followed by the number of the desired control function. Either timed or latching, and either door 1,2 or 3 functions may be controlled. The open speaker and mike tone for audio communication may also be enabled.

4.2.4.4 PIN ON ENTRANCE

This function determines which door control relay is activated when a PIN code (or a Rotary "6" from a called unit) is received by the TEC. To change the number from the default setting of 1 to another number, select "4" from the main menu. Select "4" from this sub-menu. Select the new number (from 1-4 display although only 1-3 are valid) and press the "Enter " key. You will be returned to the COMM. SETUP menu.

PIN ON ENT = 1

4.2.4.5 SITE CODE

The Site Code (sometimes called a Facility Code) is used with the optional Card Readers (OPTKCXXX where XXX = card capacity from 125 to 2000 names). Site Code is used to identify the group of cards being used with a particular TEC. This keeps cards on one facility from being used in another facility. The range of Site Codes is from 000 - 255.

To change the Site Code from the factory default of 000, press "5" from the Communications Setup menu to get to this sub-menu. Key in the desired 3 digits corresponding to the Site Code of the cards you have purchased, and press "r".

SITE CODE = 000

NOTE: IF SITE CODE = "000" THE CARD READER FUNCTION IS DISABLED, AND CARD # WILL NOT APPEAR IN CODE/NAMES PROGRAMMING MENU . IF SITE CODE IS SET TO 255, THE SITE CODE ON THE CARD WILL BE IGNORED, AND SECURITY OF CARDS WILL BE REDUCED.

4.2.4.6 TV LCD CONFIGURATION

This selection controls:

- A) How many columns are displayed.
- B) Which of three character sizes are displayed.
- C) Whether line spacing is single or double.
- D) Whether names scroll, and how fast.
- E) Whether code position is to the left or right of the name.
- F) Whether instructions are for handset or handsfree models, or ignored.

Character size 1 is the smallest character size TecVision supports.

Character size 2 is twice as big as character size 1, and character size 4 is four times as big. 1, 2, and 4 are the only choices.

Character size 4 will display a maximum of 20 characters on the screen, which includes the code numbers.

**NUM OF COL <1 - 3>
CHARSIZE <1, 2, 4>
S/D SPACE <1 - 2>
AUTO SCROLL <0 - 9>
CODE POS. <0 - 1>
INST. TYPE <0 - 2>
221000**

4.2.4.7 KEYPAD ON / OFF

This selection allows the keypad to remain active after dial out. This is useful for ATM machines, voice mail, and other functions requiring a Touch-Tone™ signal after communications are established. To enable keypad from the factory default of 0, press "7" from the Communications Setup menu to get this sub-menu. Press "1" to enable the keypad, and press "r". Only the number keys are active, r and # will not work.

KEYPAD ON = 0

4.2.4.8 SPEAKER TONE

This selection allows the speaker to be activated for remote control from a telephone in order to listen in. When enabled, the TEC has an open audio channel to permit conversation from someone calling in to the TEC(the microphone is also enabled at the same time). To enable speaker from the factory default of 0 (disabled), press "8" from the Communications Setup menu to get this sub-menu. Select a digit from 1 to 9 to enable speaker, and press "r". This will return you to the Communications Setup menu.

SPKR TONE = 0

4.2.4.9 UPDATE LCD

This selection allows information in the Tec memory contents to be transferred to the display memory contents. Press 9 to enable update, and press "r". This will return you to the Communications Setup menu.

UPDATING

4.2.5 CLOCK SETUP

**CLOCK SETUP
SELECT 1 - 3**

This is an option (OPTKCLK) whose function is selected from the Main menu by pressing "5", you will see the display message at left.

**NO CLOCK
<r> TO CONTINUE**

If you select "1", the error message shown will display, unless you purchased the optional clock module.

Press "r" to return to the Main menu.

4.2.5.0 CLOCK SETUP

**CLOCK SETUP
SELECT 1 - 3**

If you have purchased the Clock option (OPKCLK) there are three menu choices that are:

1. Set time and date.
2. Set time zone(s).
3. Set Holidays.

4.2.5.1 SETTING TIME / DATE

NOTE: ONCE TIME/DATE PROGRAMMING HAS BEGUN, ALL SELECTIONS MUST BE COMPLETED FOR CHANGES TO TAKE EFFECT.

00:00 00/00/00
MIN.:

Select "1" to set the time & date.
You will be prompted to enter the current time in minutes as a one or two digit number. If you make a mistake, press "0" and "#" simultaneously to backspace one character. After the minutes are entered, press the "r" key.

00:00 00/00/00
HOUR:

Enter a 1 or 2 digit number to set the hour. If a mistake is made, press "0" and "#" simultaneously to backspace one character. After the hour is entered, press the "r" key.

00:00 00/00/00
DAY, 1..7:

This is NOT the day of the month. This is a number which corresponds to the day of the week. Enter a number corresponding to the day of the week. Sunday is "1", Saturday is "7" and so forth. If you make a mistake, press "0" and "#" simultaneously to backspace one character. After the day of the week is entered, press the "r" key.

00:00 00/00/00
DATE:

Enter a 1 or 2 digit number to set the day of the month. If a mistake is made, press "0" and "#" simultaneously to backspace one character. After the day is entered, press the "r" key.

Enter a 1 or 2 digit number to set the month. If you make a mistake, press "0" and "#" simultaneously to backspace one character. After the month is entered, press the "r" key.

00:00 00/00/00
MONTH:

Enter a 2 digit number to set the year. If you make a mistake, press "0" and "#" simultaneously to backspace one character. After the year is entered, press the "r" key.

00:00 00/00/00
YEAR:

You will be returned to the Clock Setup menu.

4.2.5.2 SETTING TIME ZONES

A time zone is a period of time that limits when the TEC is valid. Use this to control access to a facility, when a given condition is valid, based on:

- 1) The time of day.
- 2) The day of the week.
- 3) Whether or not the day of the week is a Holiday.

A time zone is valid only within a 24 hour period that begins at midnight. A time zone has a start time and an ending time. This can be as short as two minutes, or as long as 24 hours. This time period is valid in combinations from 1 to 7 days and Holidays. There are 8 time zones numbered 0 - 7 available for use on a TEC.

Holidays may be set up at any time. A time zone can have valid Holidays, or invalid Holidays. A time zone can be set that is only valid on Holidays, for applications that require different hours of access on Holidays.

From the main menu, select "5" for clock setup, then "2" for time zone.

TIMEZONE <0-7>

You will be prompted to select a time zone between 0 and 7. If you make

**TECVISION Series v 3.1X
GUIDE**

2 DOOR INSTALLATION AND USER

a mistake, press "0" and "#" simultaneously to backspace one character. Once programming of a time zone is begun, all choices must be keyed in or you will be returned to the beginning of the time zone menu.

After the time zone is selected, press the "r" key. You will be prompted to key in the hour. This is a 1 or 2 digit number. The hour is expressed in 24 hour format (e.g., 2:25 P.M. is keyed in as 14:25), from 00:00 to 23:59.

If you make a mistake, press "0" and "#" simultaneously to backspace one character. After the hour is entered, press the "r" Key.

START HOUR 00

You will be prompted to key in the minute. This is a 1 or 2 digit number between 00 and 59.

If you make a mistake, press "0" and "#" simultaneously to backspace one character. After the minute is entered, press the "r" key.

START MIN 00

Next, enter the ending hour. This is a 1 or 2 digit number. If you make a mistake, press "0" and "#" simultaneously to backspace one character. After the hour is entered, press the "r" key.

END HOUR 23

END MIN 59

Enter the ending minute. This is a 1 or 2 digit number between 00 and 59. If you make a mistake, press "0" and "#" simultaneously to backspace one character. After the minute is entered, press the "r" key.

DAYS 12345678

Enter the desired day(s). Do this by keying in the number corresponding to the day of the week (1 = Sunday, 7 = Saturday and 8 = Holidays). As an example Monday through Friday would be keyed in as 2, 3, 4, 5 and 6. Days may be entered in any order. If you make a mistake, press "0" and "#" simultaneously to backspace one character. After all days are chosen, press the "r" key.

The table below may be used to help keep track of which Time Zones are required for this installation. Writing them down in the table provided will help reduce programming entry errors.

TIME ZONE NUMBER	START TIME		END TIME		DAYS OF THE WEEK							
	Hours	Min.	Hours	Min.	1	2	3	4	5	6	7	
	HH	MM	HH	MM	8							
					Sun	Mon	Tue	Wed	Thu	Fri	Sat	Hol
0												
1												
2												

3													
4													
5													
6													
7													

4.2.5.3 SETTING HOLIDAYS

HOLIDAY <0-8>

Holidays can be used to keep time zones valid (or not) on Holidays, or by setting a different time zone to be valid for a different period of time on a Holiday. There are 9 Holidays numbered 0 - 8 available for use on a TEC.

Select "3" to set the Holiday. Holidays may be entered in any order.

You will be prompted to select a Holiday between 0 and 8. If you make a mistake, press "0" and "#" simultaneously to backspace one character.

MONTH:

After the Holiday is selected, you will be prompted to key in the month. This is a 1 or 2 digit number.

If you make a mistake, press "0" and "#" simultaneously to backspace one character. Press the "5" key after the month is entered.

DATE:

After the month is selected, you will be prompted to key in the date. This is a 1 or 2 digit number between 1 and 31. If you make a mistake, press "0" and "#" simultaneously to backspace one character. After the date is entered, press the "5" key.

The table below may be used to help keep track of which Holidays are required for this installation. Writing them down in the table provided will help reduce programming entry errors. Remember, Holidays may be entered in any order.

HOLIDAY NUMBER	MONTH	DAY	HOLIDAY NAME
0			
1			
2			
3			
4			
5			
6			
7			
8			

4.2.6 ACCESS CONTROL

Access Control from a TEC is based on four general sets of conditions:

- 1) When a resident (who has been called from a TEC) keys in a valid door tone.

- 2) When a valid PIN code is presented at a door that is valid:
 - a) based on the time of day.
 - b) based on the day of week.
 - c) based on whether the day of the week is a Holiday or not.

- 3) When a valid card number is presented at a door card reader which is valid:
 - a) based on the card reader next to the entrance chosen for access.
 - b) based on the time of day.
 - c) based on the day of week.
 - d) based on whether the day of the week is a Holiday or not.

- 4) When an entrance group is valid, using automatic un-lock and re-lock.

The TEC has many combinations of access control based on these criteria. This versatility can be confusing to an installer, unless the access has been carefully defined BEFORE programming begins. The order in which to plan for an installation should be as follows:

1. Define access area. One entrance, or up to 3?
2. Define time zones.
 - What times is access allowed?
 - For Whom is access allowed? Everybody, or different groups of people?
 - What days is access to be allowed?
 - Are the time zones the same for different days, or different for different days?
 - Are Holidays used, and do Holidays require different time zones?
3. Define Access levels.
 - What time zone is valid for a given access level?
 - Which door is valid for an access level?
 - Is more than one door valid for a time zone?
4. Define Access Groups.
 - What combinations of access levels are in a group?
 - Is the access group to be used for PIN codes and Cards?
 - Is the access group to be used for automatic un-lock and re-lock?

The menu choices in this manual follow the order in which they appear on a TEC. These choices are in reverse order from how a site installation is typically planned. This is to force the installer to decide site requirements before beginning to program the TEC. The TEC was designed this way to help an unwary installer from "programming himself into a corner." There are tables associated with each section. They are there to help with site planning. It is strongly recommended they be completely filled out BEFORE attempting any programming.

4.2.6.0 ACCESS GROUPS

Access Groups are used to allow groups of individuals card or PIN access by assigning a level or combination of levels to their group. Access Group Zero is predefined as an unlimited group. Group Zero allows access 24 hours a day, ALL days of the year. Access Groups are assigned to the individuals in the Directory. If you do not assign a Group to an individual during the directory entry, Zero (0) is assigned by default.

Since Access Levels have different Time Zone and entrance combinations, this creates many combinations for control of an entrance based on PIN, Card, or time of day.

Once Access Groups are enabled (see section 4.2.1.8), an Access Group number for a given code number MUST be specified.

The primary application for Access Groups is for automatic Unlocking and Relocking Entrances 1 - 3. An Access Group also may be one that has no valid Access Levels when it is needed to prevent entrance access.



From the main menu select "6" for Access Control.

TECVISION Series v 3.1X

4.2.6.1 SELECTING AN ACCESS GROUP



GROUP 1 - 7

Select "6" from the main menu. Press the "r" key from the front door key pad, or the Enter key from a terminal.

Select "1" from this sub-menu. You will be prompted to select a group from 1 - 7 as shown at left. Press the "r" key from the front door key pad, or the Enter key from a terminal.

4.2.6.2 SELECTING AN ACCESS LEVEL



LEVELS - - - - -

After selecting a group, you will be prompted for levels. These are any combinations from 0 - 7 in any order. To change access levels for a given group, key in the new levels desired and press the "r" key from the front door key pad, or the Enter key from a terminal. To delete access levels entirely refer to section 4.2.8.3 Clear Access Levels.

4.2.6.2.0 ACCESS LEVELS

Access Levels are used to attach Time Zones to specific Entrances. Only one Time Zone is allowed per Access Level. Any combination of entrances may be selected, but at least one entrance must be selected, or the affected Access Level will not function.

From one to three entrances may be assigned to an Access Level. Different combinations of control may be created. Do this by assigning one entrance a Time Zone and an Access level, and another entrance the same Time Zone but a different Access Level. Now these Access Levels can be grouped in different combinations for the Access Groups.

4.2.6.2.1 PROGRAMMING AN ACCESS LEVEL

Select "6" from the main menu. Press the "r" key from the front door key pad, or the Enter key from a terminal.

Select "2" from this sub-menu. You will be prompted to select a level from 0 - 7 as shown at right. Press the "r" key from the front door key pad, or the Enter key from a terminal.



LEVEL <0 - 7>

4.2.6.2.2 SELECTING A TIME ZONE

You will be prompted to select a time zone from 0 - 7 as shown at right. Select the desired zone number and press the "r" key from the front door key pad, or the Enter key from a terminal.



TIME ZONE <0 - 7>

4.2.6.2.3 SELECTING A DOOR

You will be prompted to select a door 1 - 4 as shown at right. Select

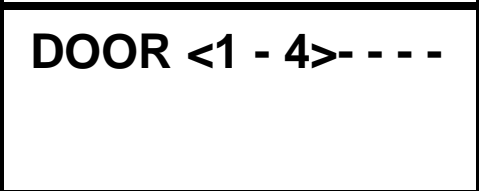

DOOR <1 - 4>- - - -

the desired door combination and press the "r" key from the front door key pad, or the Enter key from a terminal. Door 4 will never be valid, although it can be selected as a choice. Door 3 may or may not be valid, depending on the configuration of the Tec unit, and options selected.

Use the table below to help keep track of which Access Levels are required for this installation. Writing them down in the table provided will help reduce programming entry errors.

ACCESS LEVELS	TIME ZONE	Entrance 1	Entrance 2	Entrance 3	Entrance 4 (not used)
AL0					
AL1					
AL2					
AL3					
AL4					
AL5					
AL6					
AL7					

4.2.6.3 AUTOMATIC UNLOCK AND RELOCK BY TIME ZONE

The example on the next page shows how a business might keep two entrances open during peak employee traffic, and secure those two entrances at all other times. Time Zone 1 is valid for one half hour in the morning, Monday through Friday. Time Zone 2 is valid for one half hour in the afternoon, Monday through Friday. Time Zone 0 is valid all the time, except Holidays.

Each Time Zone is assigned to a different Access Level. Both entrances are selected in the Access Levels. The morning and the afternoon Access Levels are grouped together in Access Group 1.

By setting Entrance Group 1 to Access Group 1, the entrance will automatically unlock during peak traffic, and relock at all other times. Employees whose PIN codes or cards are set to Access Level 0, can open the entrance at all other times. If employees try to use their PIN code while the entrances are unlocked, the display on the TEC will show "OPEN".

4.2.6.3.1 EXAMPLE OF AN AUTOMATIC UNLOCK APPLICATION

TIME ZONE NUMBER	START TIME		END TIME		DAYS OF WEEK							
	Hour	Min.	Hour	Min.	1	2	3	4	5	6	7	8
	HH	MM	HH	MM	Sun	Mon	Tue	Wed	Thu	Fri	Sat	Hol
0 ALWAYS ON	00	00	23	59	/	/	/	/	/	/	/	/
1 INCOMING (MORNING)	07	45	08	15		/	/	/	/	/		
2 OUTGOING (AFTERNOON)	16	45	17	15		/	/	/	/	/		
ACCESS LEVELS					TIME ZONE	DOOR 1	DOOR 2					
AL0 (VALID 24 HOURS PER DAY)					0	1	2					
AL1 (USES TIME ZONE 1 MORNING HOURS M - F)					1	1	2					
AL2 (USES TIME ZONE 2 AFTERNOON HOURS M - F)					2	1	2					

TECVISION Series v 3.1X

ACCESS GROUPS	ACCESS			LEVELS				
	AL 0 7	AL 1	AL 2	AL 3	AL 4	AL 5	AL 6	AL 7
AG1 (AUTO UNLOCK)		TZ 1	TZ 2					
AG2 (24 HOUR)	TZ 0							

These are shorter versions of the other tables in this manual. Start by defining which entrance is to be unlocked, for how long, on which days. This is the time zone data. Next, define which combinations of doors are controlled by a time zone. This is an access level. Last, group access levels into an access group. The Entrance Group is that access group number.

4.2.7 TRANSACTION BUFFER INFORMATION

This option will only be present if:

- 1) You purchased an optional clock and capacity with names is less than 1000 names.
- 2) If you purchase an optional extended transaction buffer (OPTKXBUF).

The transaction buffer stores any event that would normally create a logging printer message. For examples of report messages, see section 14.1.1. The size of the transaction buffer depends on the capacity of the TEC. Usually, the smaller the capacity the larger the transaction buffer space.

After a transaction buffer becomes full, it begins to overwrite the oldest event in the transaction buffer storage space.

**BUFFER INFO.
SELECT 1 - 5**

Press "7" from the main menu to get the selection shown at left. If you do not have a transaction buffer installed in your TEC, a single error tone will sound (+) and the menu choice will be ignored.

Press "r" to return to the Main menu.

4.2.7.1 VIEW LOG

This allows the log to be viewed from a terminal connected to the optional serial port. The log also may be viewed from a personal computer communicating through the optional modem. Pressing "1" from the front panel keypad will only show a cursor box in the LCD display as shown at right. The TEC will sound a long error tone (+) and return to the Buffer Information menu.

\$

4.2.7.2 SEND LOG

Pressing "2" will send all logging data to either the optional serial port or to the optional modem. A message like the one at right will display.

**PRINTING BUSY
PLEASE WAIT**

After all data stored in the buffer has been sent, the message shown at right will display. Press "r" again, to return to the Main menu.

**BUFFER INFO
SELECT 1 - 5**

4.2.7.3 FIND CODE

Pressing "3" from the front panel keypad will only show a cursor box in the LCD display as shown at right. The TEC will sound a long error tone (+) and return to the Buffer Information menu. This function is designed to transmit all transactions for a given code to a terminal or modem.

\$

4.2.7.4 LOG SIZE

Press "4" to see the size of the buffer for your particular TEC. This will vary from model to model, depending on capacity and options. The upper number as shown at right is the total number of transactions before overwriting the first transaction. The lower number is the number of transactions remaining before over writing the buffer occurs. Subtracting the lower number from the upper number shows how many transactions have occurred. Depending on the amount of activity on your system, and the memory capacity of your TEC, you may wish to purchase additional buffer capacity (OPTXBUF).

**LOG SIZE = XXXX
BUFF LEFT =**

4.2.7.5 CLEAR BUFFER

Press "5" to get to the menu at right. Pressing a "1" then "r" clears all transactions stored in the buffer for the TEC. If you press a "1" by mistake, press "#" and "0" simultaneously to backspace over the "1". Press "0" then "r" to return to the main menu. If you press any key other than "1", the TEC will sound a long error tone (+). Press "r" to return to the Buffer Information menu. Press "r" again, to return to the Main menu.

**DESTROYS REC
CONTINUE? 1/0**

4.2.8 CLEAR DATA

**CLEAR DATA
SELECT 1 - 6**

This function allows selective erasing of some data stored in the TEC. This allows you to reprogram time zones or holidays without erasing all the names, codes and phone numbers. Press "8" from the main menu to get the selection displayed at left:

Press "r" to return to the Main menu.

**DESTROYS REC
CONTINUE? 1/0**

When you select any of these choices from 1 to 6, the message at left will display. If you press a "1" by mistake, press "#" and "0" simultaneously to backspace over the "1". Press "0" then "r" to return to the main menu. If you press any key other than "1", the TEC will sound a long error tone (+). Press

TECVISION Series v 3.1X

"r" to return to the Buffer Information menu. Press "r" again, to return to the Main menu.

4.2.8.1 SET PARAMETERS

This returns all Door Control, System Parameters and Communication Setup settings to the SES factory defaults. These defaults are shown on Pg. 13 and 14. Press "1" to reset the parameters.

4.2.8.2 CLEAR TIME ZONES

Pressing "2" causes this selection to clear any previously programmed time zone and resets all times to 00:00. Press "r" to return to the Main menu.

4.2.8.3 CLEAR HOLIDAYS

Pressing "3" causes this selection to clear all Holidays from memory. This is useful for Holidays that are observed on different days from year to year, such as Thanksgiving or Labor Day. Press "r" to return to the Main menu.

4.2.8.4 CLEAR ACCESS LEVELS

Pressing "4" causes this selection to clear all access levels of any previously programmed data. Press "r" to return to the Main menu.

4.2.8.5 CLEAR ACCESS GROUPS

Pressing "5" causes this selection to clear all access groups of any previously programmed data. Press "r" to return to the Main menu.

4.2.8.6 CLEAR CORRUPTED DATA

Pressing "6" causes this selection to clear all corrupted directory data. Press "r" to return to the Main menu.

4.2.9 DISPLAY DATA

This menu selection is used with an optional printer (OPTPRT), or a CRT or terminal for sub-menu choices 1 through 5. Data is sent to the optional serial port. It is used to print various parameters, such as Time Zones, Holidays, Access Levels, Access Groups and general Information. Sub-menu choices 6 through 9 send data to the LCD display on the front panel of the TEC. To select this function, press "9" from the Main Menu. You will see the display, shown below.

**PRINTING BUSY
PLEASE WAIT**

Pressing any selection from "1" to "5" will cause the display at left, to be shown briefly.

4.2.9.1 PRINT INFO

Pressing "1" will send the system configuration information (like the example below) for this TEC to a CRT or printer.

```
VER 3.XX  
CODE CAP = 0110  
PHONE CAP = 0100  
CODE LENGTH = 3  
PIN LENGTH = 4  
CR BIT TYPE = 1  
ENA ACC GRP = 0  
PRESS # TO VIEW
```

DIRECTORY
PROGRAM PSWD = 777777

4.2.9.2 PRINT TIME ZONES

Pressing "2" will send time zones (4.2.9.2) to a CRT or printer.

ZONE	STIME	ETIME	SMTWTFSH
0	00:00	23:59	1234567---
1	07:45	08:30	-23456----
2	16:30	17:15	-23456----
3	00:00	00:00	-----
4	00:00	00:00	-----
5	00:00	00:00	-----
6	00:00	00:00	-----
7	00:00	00:00	-----

4.2.9.3 PRINT HOLIDAYS

Pressing "3" will send holidays (4.2.9.3) to a CRT or printer.

HOL	MONTH	DATE
0	00	00
1	00	00
2	00	00
3	00	00
4	00	00
5	00	00
6	00	00
7	00	00
8	00	00

4.2.9.4 PRINT ACCESS LEVELS

Pressing "4" will send all Access Levels (4.2.9.4) to a CRT or printer.

LEVEL	DOOR	TZ	STIME	ETIME	SMTWTFSH
0	123-	0	00:00	23:59	1234567-
1	12--	1	07:45	08:30	-23456---
2	1-34	2	16:30	17:15	-23456---

TECVISION Series v 3.1X

3	-23-	0	00:00	23:59	1234567-
4	-----	0	00:00	23:59	1234567-
5	-----	0	00:00	23:59	1234567-
6	-----	0	00:00	23:59	1234567-
7	-----	0	00:00	23:59	1234567-

4.2.9.5 PRINT ACCESS GROUPS

Pressing "5" will send Access Groups (4.2.9.5) to a CRT or printer. In this example, 2 Access Groups of the possible total of 7, are shown.

AG	AL	DOOR	TZ	STIME	ETIME	SMTWTFSH
1	1	12-4	1	07:45	08:30	-23456--
	2	123-	2	16:30	17:15	-23456--
2	0	-23-	0	00:00	23:59	1234567-

4.2.9.6 DISPLAY TIME ZONE

Pressing "6" displays the time zone information on the LCD display located on the front panel of the TEC. When first selected, the display defaults to the data in Time Zone 0 shown at right. Press any key from 0 through 7 to see the data for Time Zones 0 through 7. If you press an "8" or a "9," the TEC sounds an error tone. Press "r" to return to the Display Data menu.

TZ0 00:00 00:00
DAYS _____

4.2.9.7 DISPLAY HOLIDAYS

Pressing "7" displays the holiday information on the LCD display located on the front panel of the TEC. When first selected, the display defaults to the data for holiday 0 shown at right. Press any key from 0 through 8 to see the data for holidays 0 through 8. If you press "9," the TEC sounds an error tone. Press "r" to return to the Display Data menu.

HOL MONTH DATE
0 00 00

4.2.9.8 DISPLAY ACCESS LEVELS

Pressing "8" displays the access level information on the LCD display located on the front panel of the TEC as shown at right. When first selected, the display defaults to the data in Access Level 0. Press any key from 0 through 7 to see the data for Access Levels 0 through 7. The TEC displays Access Level, the doors that are valid, and the Time Zone selected for that Access Level. If you press an "8" or a "9," the TEC sounds an error tone. Press "r" to return to the Display Data menu.

LEVEL DOOR TZ
0 _____ 0

4.2.9.9 DISPLAY ACCESS GROUPS

Pressing "9" displays the Access Group information on the LCD display located on the front panel of the TEC as shown at right. When first selected, the display defaults to the data in Access Group 0. The TEC displays Access Group and the Access Levels that are valid for that Access Group. Press any key from 0 through 7 to see the data for Access Groups 0 through 7. If you press an "8" or a "9," the TEC sounds an error tone (+). Press "r" to return to the Display Data menu.

GROUP LEVELS
0 _____

5.0 S1 SWITCH SELECTION DESCRIPTIONS

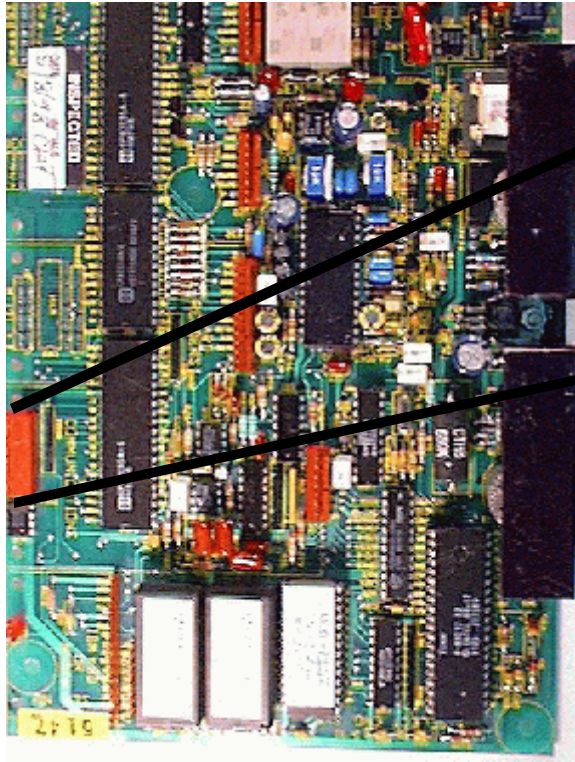

- | | | |
|---|----------------------|---|
| 1 | — PROGRAM ENABLE | } FACTORY
SETTINGS
DO NOT
CHANGE |
| 2 | — SPKR ENABLE | |
| 3 | — ALWAYS OFF | |
| 4 | — TecVision ENABLE | |
| 5 | — CARD DIAG. | |
| 6 | — 2RDR=OFF / 4RDR=ON | |
| 7 | — ALWAYS ON | |
| 8 | — RESET | |
| 9 | | |

NOTE: PC BOARD ORIENTATION ON TECVISION DIFFERENT FROM THIS DRAWING.

5.1 SPEAKER AND MIKE ADJUSTMENTS

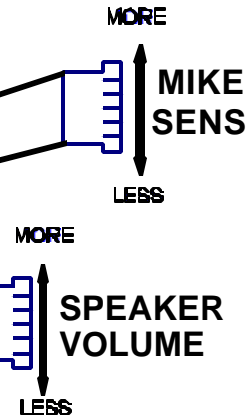
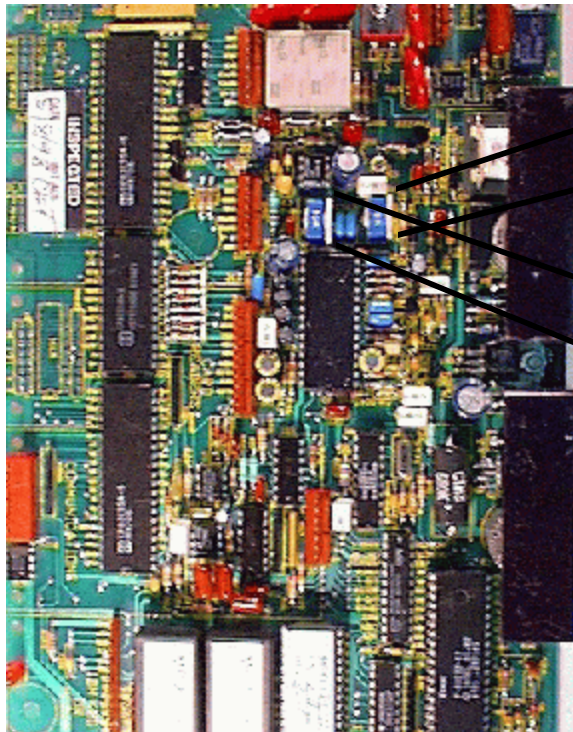

5.2 POWER SWITCH LOCATION

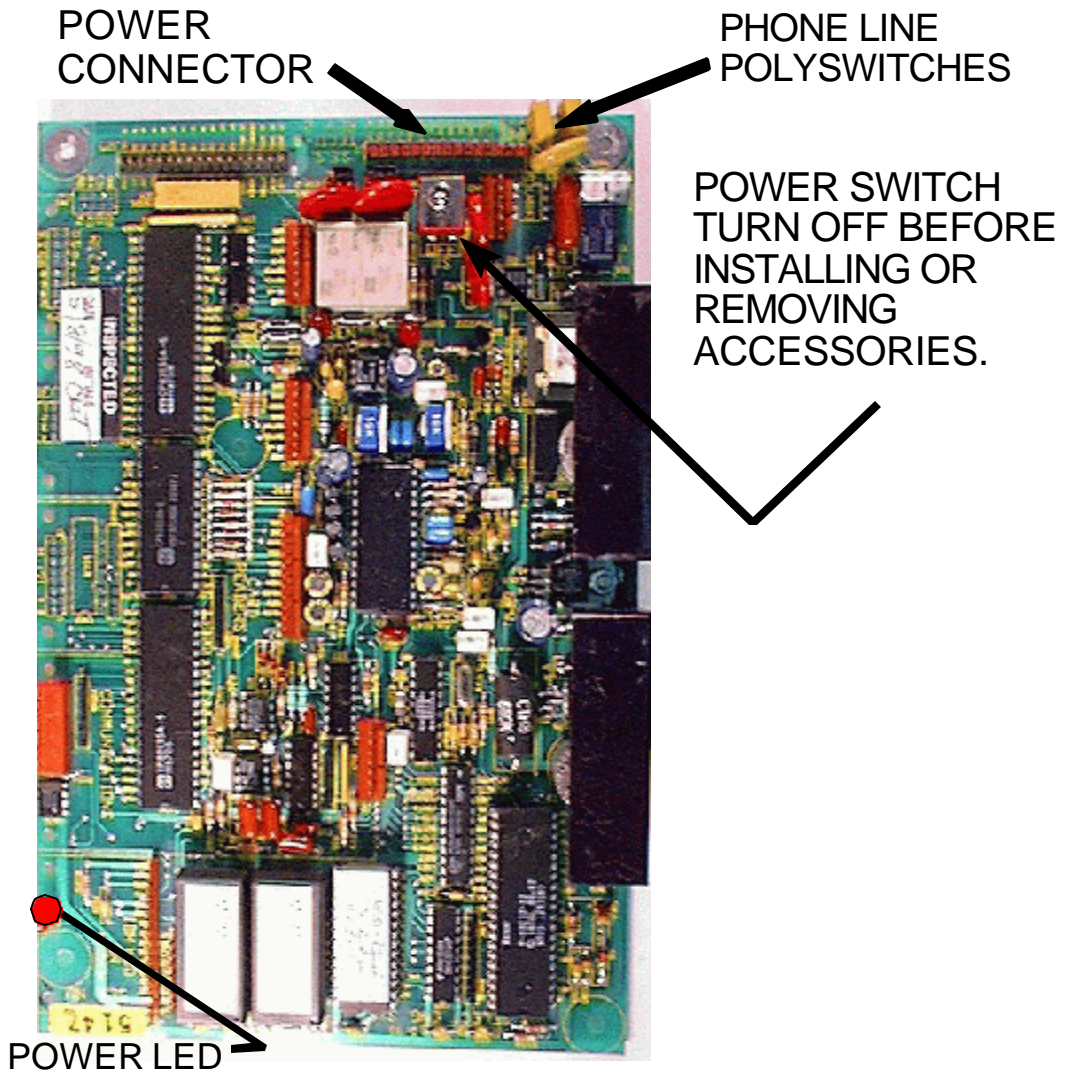

6.0 REMOTE CONTROL OF TEC

The following functions can be remotely controlled by using a Touch-Tone™Telephone.

- A. Activating the Entrance Relays.
- B. Latching open the Entrance relays.
- C. Un-latching the Entrance relays.
- D. Opening the microphone and speaker remotely.

6.1 REMOTELY ACTIVATING OUTPUT RELAYS

All factory defaults will be assumed in these examples. If you have changed any of the factory defaults, use your corresponding changes for the examples.

NOTE: IF USING AUTO UNLOCK AND RELOCK, ANY LATCHED FUNCTION WILL BE OVERRIDDEN BY THE SYSTEM CLOCK ENTRANCE GROUP FUNCTION. SEE SECTION 4.2.2.3.

6.1.1 REMOTELY ACTIVATING PRIMARY RELAY (TIMED)

1. Call the phone number connected to the TEC.
2. After three rings wait for a tone (*).
3. Press the first digit of the password ("7") and wait for the answer tone (*). After each key press, an acknowledgment tone will occur, letting you know that the TEC received (heard) the key you pressed from your phone.
4. Press the second digit of the password ("7") and wait for the acknowledgment tone (*).
5. Press the "r" key and wait for the "password accepted" tone, which is two beeps following the acknowledgment tone (* **). If you make an error, (like an incorrect password) a long error tone (+) will be heard, and the TEC will hang up.
6. Press the Entrance 1 Open tone, which is "6". The Entrance 1 relay will energize.
7. Press "0" to hang up.

It should be noted that, unlike other SES products, after opening a door, the TEC does not hang up automatically. Other relay functions such as timed or latched, speaker/mike open, etc. can be entered, until you press a "0".

6.1.2 REMOTELY ACTIVATING PRIMARY RELAY (LATCHED)

1. Get into Remote Control Mode by following section 6.1.1 steps 1 through 5.
2. Press the Entrance 1 Latch tone. Since the factory default tone is "0", the TEC will hang up, if a "0" is pressed. A different number other than the Entrance 1 Open tone must be programmed in the Entrance 1 Latch (section 4.2.2.4) to latch open Entrance 1 control relay.
3. Press "0" to hang up.

6.1.2.1 REMOTELY UNLATCHING PRIMARY RELAY (LATCHED)

To de-activate remotely a latched relay, follow the instruction sequence from section 6.1.1 Remotely Activating Primary Relay Timed. This will cause the door to re-lock after Entrance 1 times out.

NOTE: IF ENTRANCE 1 OPEN TONE AND ENTRANCE 1 LATCH TONE ARE THE SAME NUMBER, THE ENTRANCE RELAY WILL NOT LATCH OR TIME OUT. IT WILL ENERGIZE BRIEFLY, AND THEN DE-ENERGIZE.

6.1.3 REMOTELY ACTIVATING ENTRANCE RELAYS 2 OR 3 (TIMED)

1. Get into Remote Control Mode by following section 6.1.1 steps 1 through 5.
2. Press the Entrance 2 or 3 Open tone. Since the factory default tone is "0", the TEC will hang up if a "0" is pressed. Press the programmed Entrance 2 or 3 Open tone to open the appropriate entrance relay.
3. Press "0" to hang up.

6.1.4 REMOTELY ACTIVATING ENTRANCE RELAYS 2 OR 3 (LATCHED)

1. Get into Remote Control Mode by following section 6.1.1 steps 1 through 5.
2. Press the Entrance 2 or 3 Latch tone. Since the factory default tone is "0", the TEC will hang up, if a "0" is pressed. Press the programmed Entrance 2 or 3 Latch tone to open the appropriate entrance relay.
3. Press "0" to hang up.

6.1.4.1 REMOTELY UNLATCHING ENTRANCE 2 OR 3 RELAY (LATCHED)

To de-activate remotely a latched relay, follow the instruction sequence from section 6.1.3 Remotely Activating Entrance 2 or 3. This will cause the door to re-lock after the appropriate entrance times out.

6.1.5 REMOTELY OPENING MIKE/SPEAKER CHANNEL

To remotely activate the microphone and speaker:

1. Get into Remote Control Mode by following section 6.1.1 steps 1 through 5.
2. Press the Open Speaker tone. Since the factory default tone is "0", the TEC will hang up, if a "0" is pressed. A different number must be programmed in the Open speaker tone (section 4.2.4.8) to activate the audio channel..
3. Press "0" to hang up.

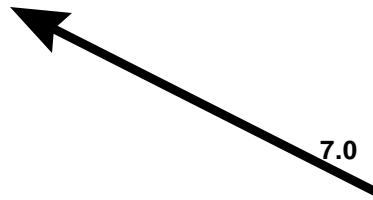

TECVISION BULBS

- 1) Open Door.
- 2) Remove screws holding Lexan.
- 3) Remove required lamp bulb.
- 4) Unclip bulbs to change.

NOTE: To maintain the lighting, refer to the diagram for changing TECVISION bulbs. The bulbs used in TECVISION have been chosen to minimize power consumption, so it is recommended that replacements be purchased from SES (P/N 31513439FL61). Bulbs purchased from national chain electronics stores will work in the TECVISION. But, they also will consume twice as much power, requiring a heavier wire gauge, and generate more heat.

8.0 ACCESSORIES OVERVIEW

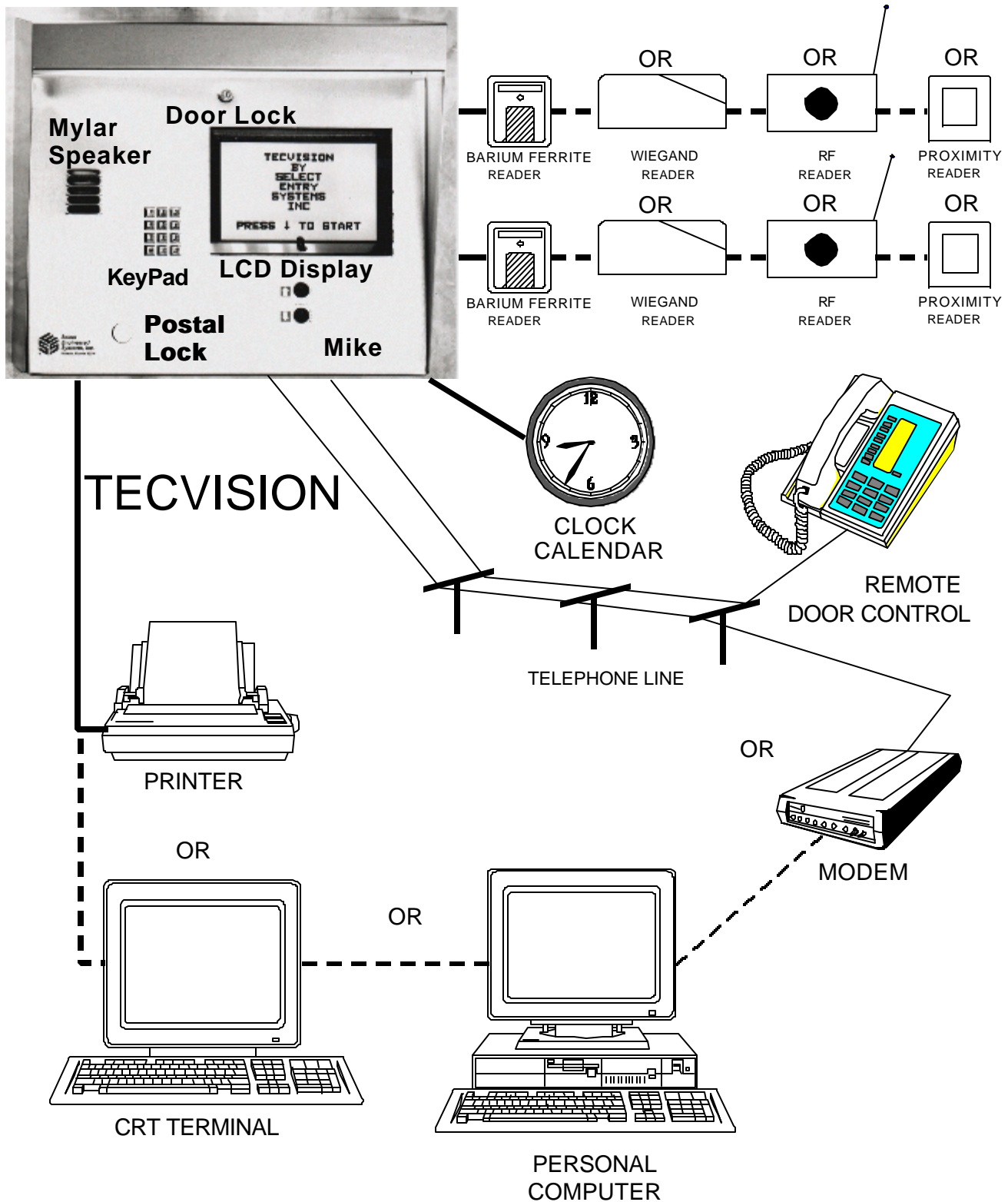

Although some options are not shown, available options are:

TECVISION Series v 3.1X

M Multiple units can share same telephone line, via MUIs (OPTKMUI).

M Ground start (OPTKGS).

M Local ringer capability.

M Printer capability (RS-232 port) or Current Loop to printer (OPTKPRT)
(Baud rates to printer and/or remote terminal (CRT) 300, 600, 1200, 2400, 4800, 9600, 19200)

M Clock & Calendar, timed automatic lock and unlock (OPTKCLK).

M Second relay (OPTK2R) has functions for Door 1 and 2 sense and door 1 and 2 shunt relay.

M Third signal relay (OPTK3R) has functions for CCTV activation, alarm output and 2 tamper inputs.

M Standby batteries (OPTB12V).

M Card reader(s) input (2 Readers)

! Wiegand, Barium Ferrite, Proximity, RF Transmitter, Magstripe (Wiegand output).

Several reader technologies using Wiegand format signals are available, including Wiegand, Barium Ferrite, Proximity, RF Transmitter, and Long Range Proximity Readers. Wiegand output keypad controllers also may be used in some situations. Contact the factory for particulars on Wiegand output keypads.

M 2 types of modems for programming over phone lines

! 1200 baud modem (OPTKMOD).

! 9600 baud modem (OPTKMODEM96).

M Two minute "sleep" function to allow programming up to 4 TEC with modem.

M Remote listen-in function.

TECVISION Series v 3.1X

M Multiple units can share same telephone line, via MUIs (OPTKMUI).

M Ground start (OPTKGS).

M Local ringer capability.

M Printer capability (RS-232 port) or Current Loop to printer (OPTKPRT)
(Baud rates to printer and/or remote terminal (CRT) 300, 600, 1200, 2400, 4800, 9600, 19200)

M Clock & Calendar, timed automatic lock and unlock (OPTKCLK).

M Second relay (OPTK2R) has functions for Door 1 and 2 sense and door 1 and 2 shunt relay.

M Third signal relay (OPTK3R) has functions for CCTV activation, alarm output and 2 tamper inputs.

M Standby batteries (OPTB12V).

M Card reader(s) input (2 Readers)

! Wiegand, Barium Ferrite, Proximity, RF Transmitter, Magstripe (Wiegand output).

Several reader technologies using Wiegand format signals are available, including Wiegand, Barium Ferrite, Proximity, RF Transmitter, and Long Range Proximity Readers. Wiegand output keypad controllers also may be used in some situations. Contact the factory for particulars on Wiegand output keypads.

M 2 types of modems for programming over phone lines

! 1200 baud modem (OPTKMOD).

! 9600 baud modem (OPTKMODEM96).

M Two minute "sleep" function to allow programming up to 4 TEC with modem.

M Remote listen-in function.

9.0 CARDS

The card reader module works with 26 or 30 bit Wiegand format bit streams. There are LED drive indicator signals on the 2 door reader. Belden 9941 is used to connect readers to the card reader module.

CARD READERS

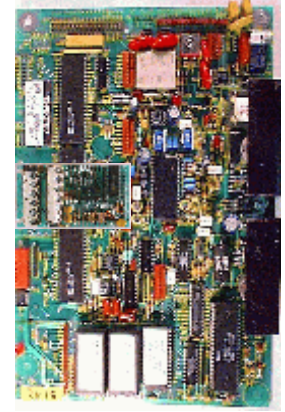

9.1 CARD READER VOLTAGE SELECT

There are jumpers on the card reader board to select 5 or 12 volts for various reader types. Many WIEGAND swipe, insert or key readers are 5 volts. Many BARIUM FERRITE, PROXIMITY and INFRARED readers are 12 volts. If the readers and the card option were purchased together, this has already been configured. If not, see the diagram below to select the appropriate card reader voltage setting. Check with the manufacturer of your card reader for correct voltage selection.

Note that the card reader and relay assignments cannot be mixed. Card Reader 1 will ALWAYS control the first relay. This is the relay on the terminal barrier strip to the left of the mother board. Card Reader 2 will ALWAYS control the 2nd relay output on the terminal barrier strip to the left of the mother board.

The maximum distance for WIEGAND readers is 500 feet. Belden #9941 or close equivalent must be used for card reader signals.

The maximum distance for BARIUM FERRITE, PROXIMITY, or INFRARED readers is 100 feet, using Belden #9941. For distances up to 500 feet use Belden # 83656, or close equivalent.

The maximum power consumption available for using on-board power supply is 125 ma. per reader. For readers with greater power requirements, an external power supply MUST be used.

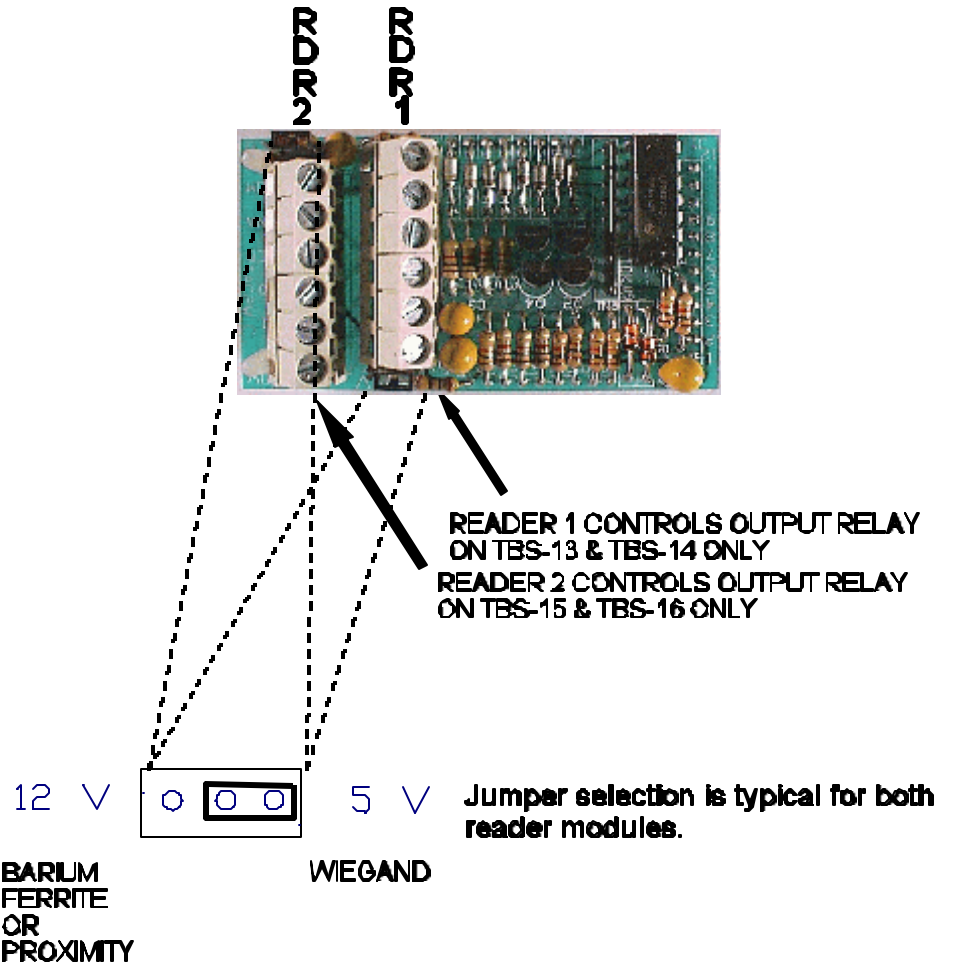

9.2 GROUNDING CARD READER WIRING

NOTE: DO NOT WIRE ANY PORTION OF THE CARD READER "HOT." REMOVE ALL POWER BEFORE WIRING ANYTHING TO THE CARD READER.

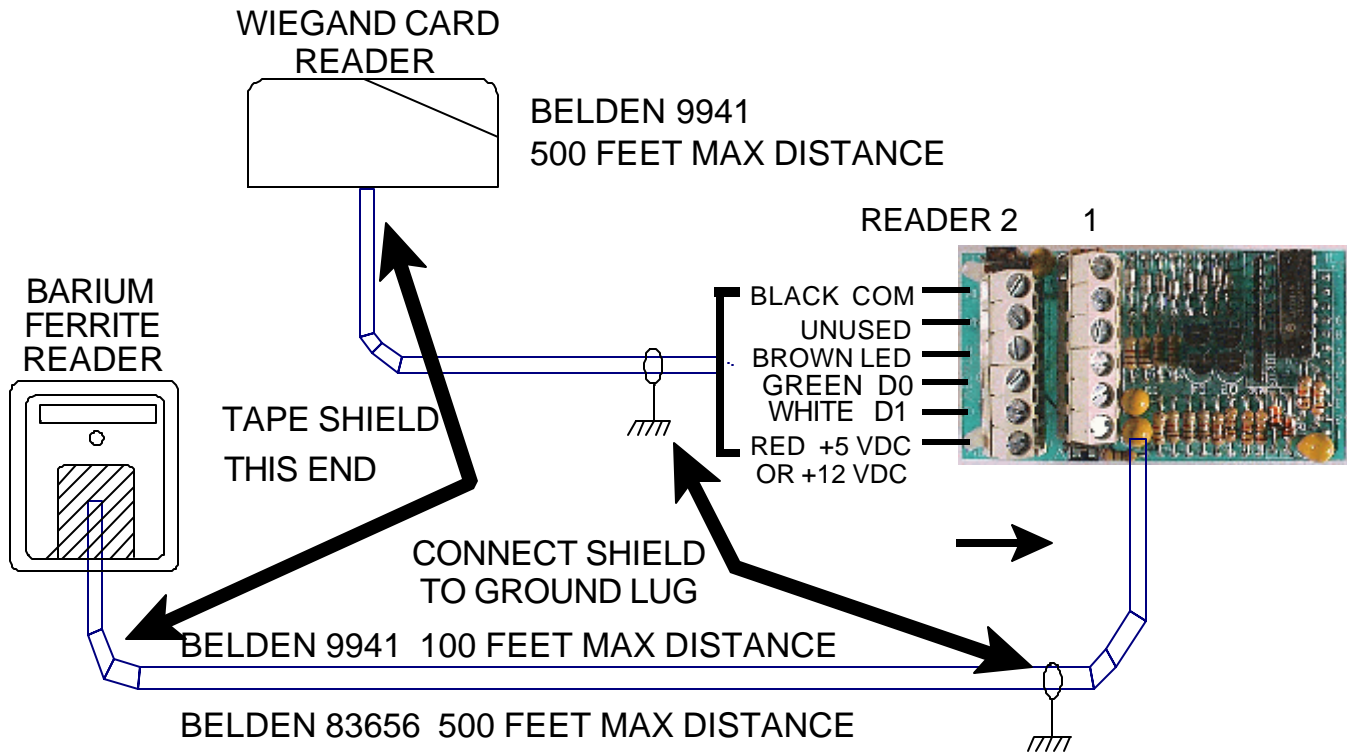

As the above drawing shows, grounding the card reader correctly is very important. Since the ground lug for the TEC is near the top of the unit, take care to avoid shorting the card reader cable shield to components on the mother board.

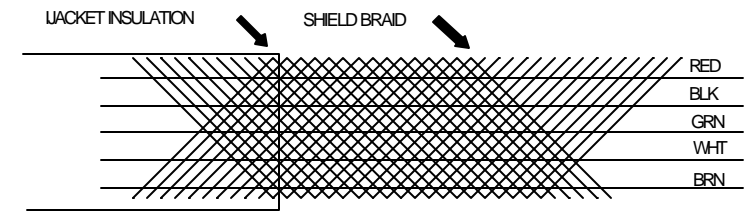

Strip away 3 inches from the outer jacket, as shown at left.

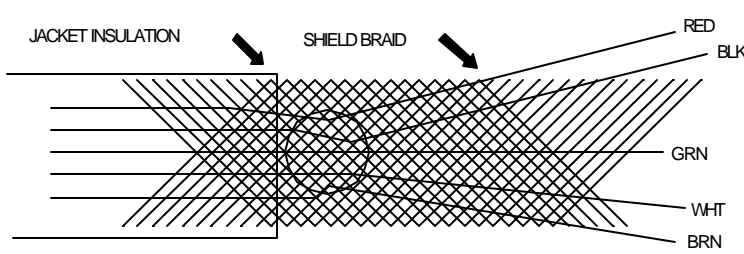

Poke a hole in the braid as shown at left. Spread the braid open, so the conductors are visible. Peel the conductors out, taking care not to damage the insulation on the conductors.

Attach an insulated #18 gauge stranded wire to the shield with a wire nut. Allow enough length for the insulated #18 wire to reach the ground lug in the back of the TEC back box.

Tape the shield from the cable to the wire nut to prevent shorting to any components on the TEC PC board.

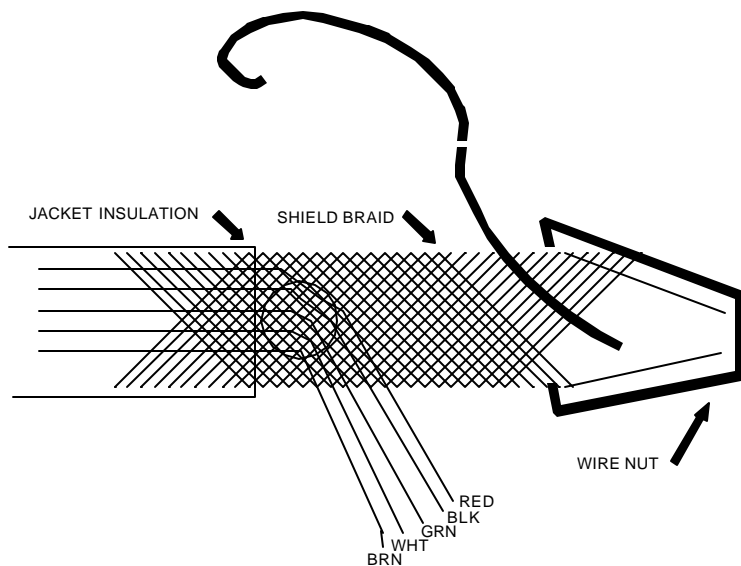

9.3 CONNECTING CARD READER WIRING

Strip 3/16" insulation from the conductors. Fold the stripped portion of the conductor over the insulated portion. Insert the wire in the clamps of the screw terminals on the card reader board and clamp down by screwing the terminal screw tightly. This ensures a good mechanical connection and an electrical connection that will keep the small wires from breaking.

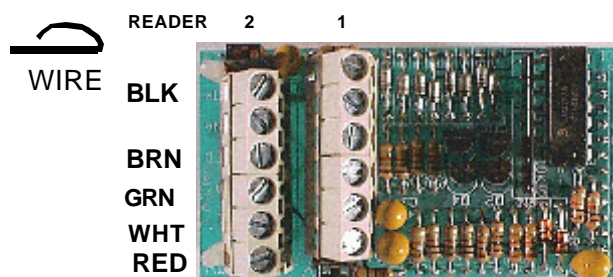

9.4 SITE CODE

To keep a card (for example card number 12345) from being used from another facility, a Site Code is set in the TEC. This is the same as a Facility Code would be in a commercial card reader installation. Set the Site Facility Code using section 4.2.4.5.

If the Site code (of the cards) is not known, turn on #5 on the dip switch on the main PC board. This will display card errors on the LCD screen on the front door. Swipe a card through a reader and read the site code error information on the LCD display to determine the Site code. After the Site code is entered turn switch 5 off, to keep swiped card numbers confidential.

To have the Tec unit ignore the site code completely, enter 255 as a site code. This diminishes the security of the facility, as a card from some other facility that was coincidentally the same number as a valid card, could operate the reader. This is sometimes necessary when mixing card technologies on a site, but should only be done as a last resort.

9.5 SETTING WIEGAND FORMAT

While there are several Wiegand output formats, the two used by SES are 26 and 30 bit Wiegand output. The factory default from SES is 30 bit output. To set the bits to 26, enter 260 as a site code number (See section 4.2.4.5). To set the bits to 30, enter 300 as a site code number. Neither of these numbers will change the existing Site code.

10.0 MUI

The Multiple Unit Interface (OPTKMUI) is an optional device that allows up to 8 TEC's to share a phone line. While it is preferred that each TEC have its' own phone line, it is sometimes necessary to share an existing line for cost effectiveness. Whenever a TEC goes off hook, all other TEC units sharing that same phone line will display a "Phone Line Busy Please Wait" message on the LCD display.

The MUI also is required for installations that use modems but want to share phone lines with other equipment that also makes use of modems. (See section 15.5).

Something to consider when deciding how many phone lines to get for a multiple unit installation, is the number of residences each TEC will call. This will help determine the optimum number of phone lines in balancing cost versus convenience against anticipated telephone usage.

To install a MUI, power down the TEC, and plug the module into the header. Note that the TEC power switch will be to the left of the MUI module.

MUI's may be attached to their common phone line by running the phone line pair from TEC to TEC, or from some common point to all TEC locations. This provides a lot of installation flexibility.

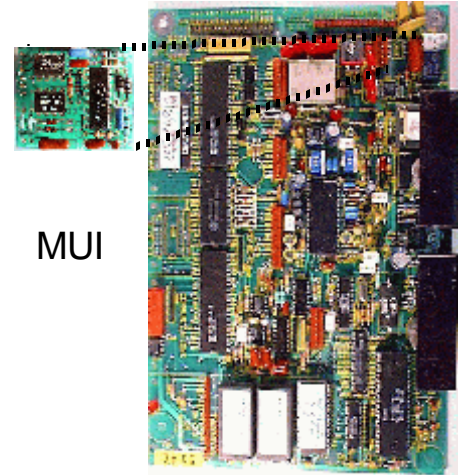

MUI

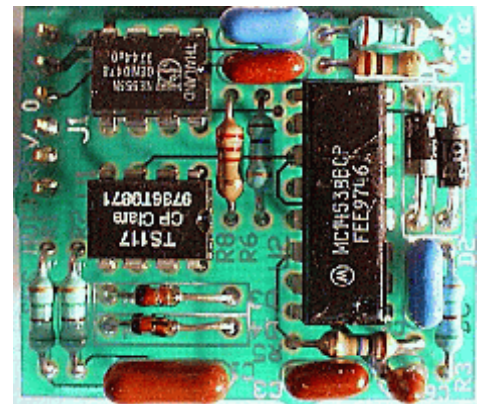

11.0 GROUND START

The ground start option (OPTKGS) is installed only at the factory, directly on the TEC main circuit board. This is necessary in some parts of the country that require a momentary connection to earth ground to initiate a dial tone. For further questions, consult the factory.

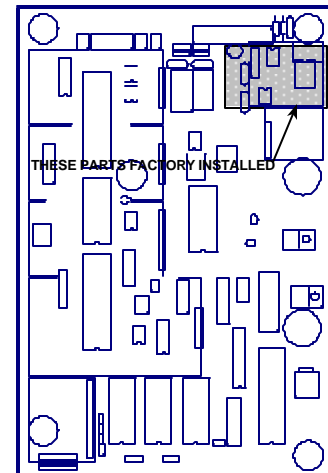

12.0 OPTK2R RELAY MODULE

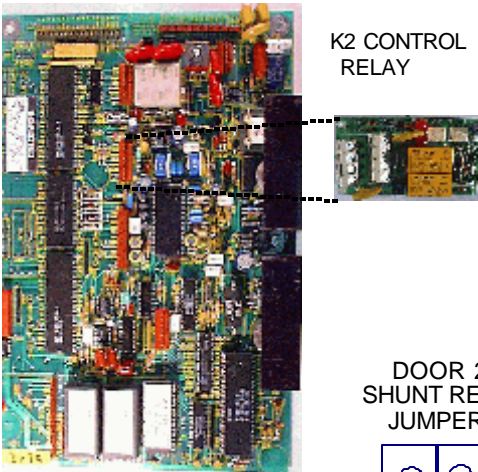

Use the optional relay module to control the door sense and shunt functions for Doors 1 & 2.

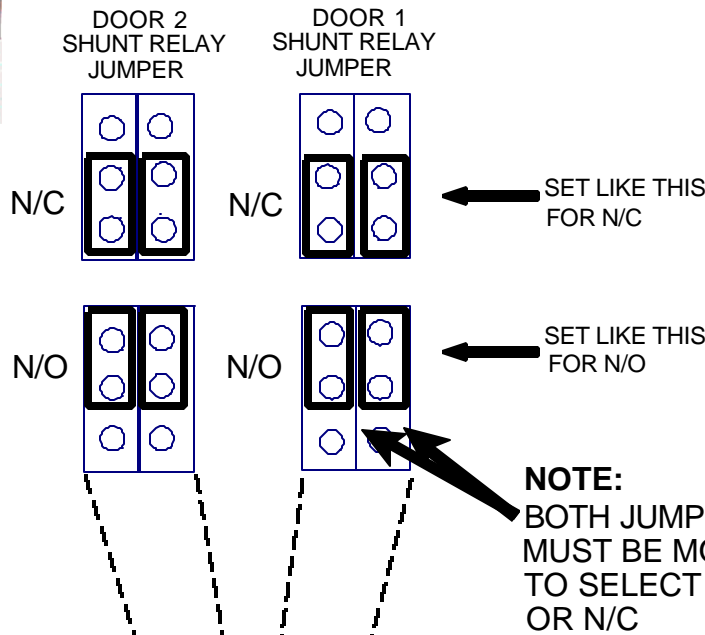

The relay capabilities are 48 volts AC or DC at 3 amp. Form "A" (N/O) or form "B" (N/C) contacts are on the shunt relay for controlling devices. These are jumper selected (see left).

Note that jumpers for relay selection must be moved in pairs. This is to provide sufficient current capacity for the controlled device.

If additional current capabilities are required, it is recommended that the shunt relay be used to control a larger relay or contactor. For further questions, consult the factory.

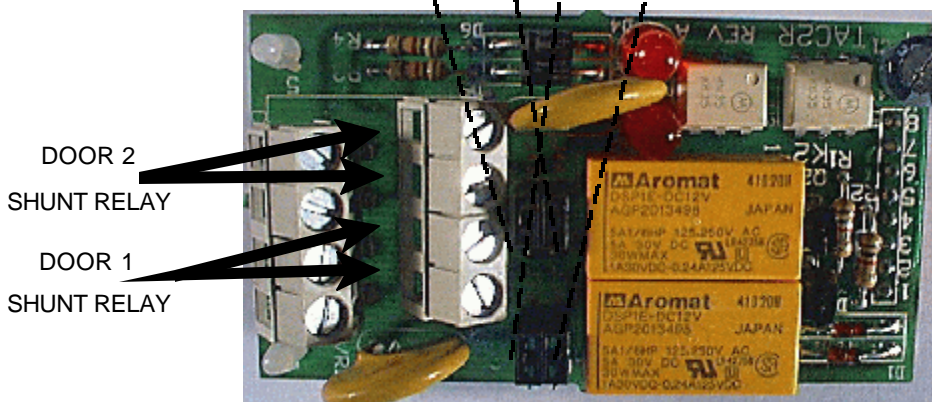

RELAYS MAY BE SET IN ANY COMBINATION

FACTORY SETTINGS ARE NORMALLY OPEN (N/O)

The Sense 1 and Sense 2 signal inputs are "dry" contact inputs only. These inputs are normally open and actuate the ajar timer upon contact closure. To simplify troubleshooting in the field, an LED indicator lights whenever the input signal is closed.

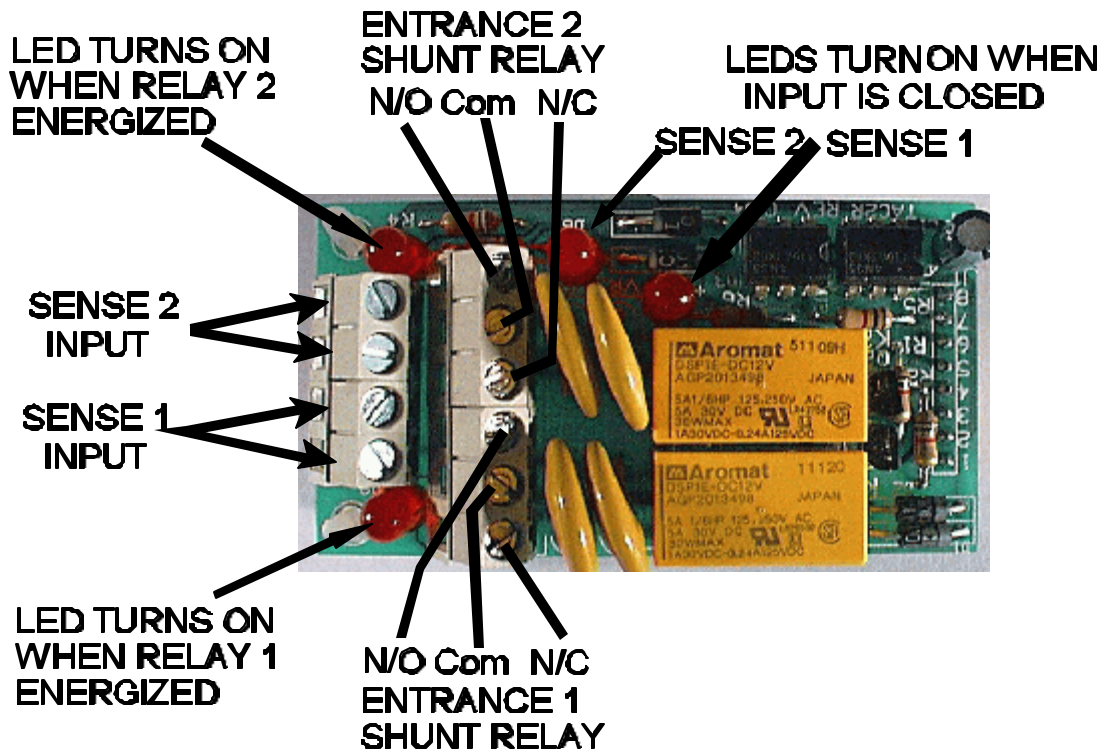
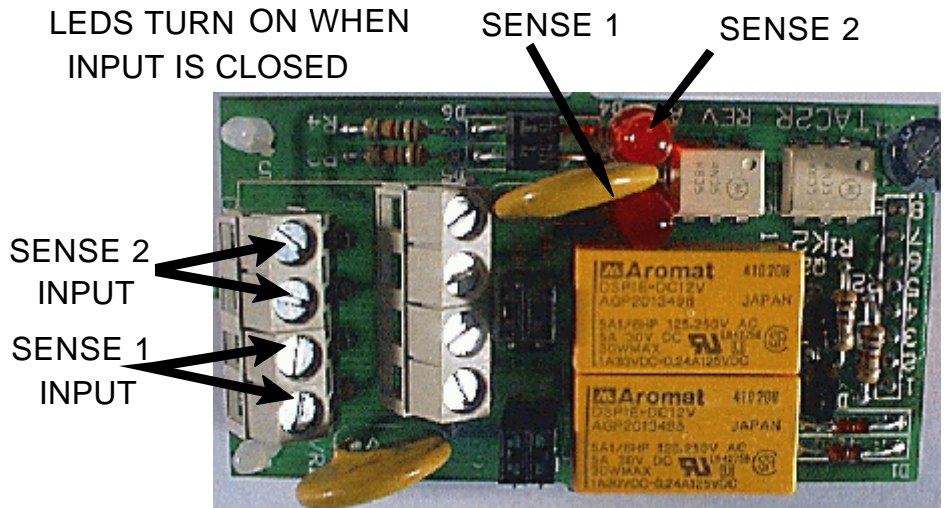

For applications requiring a Form C relay, a similar module (OPTK2FRMC) is available.

13.0 K3 CONTROL RELAY

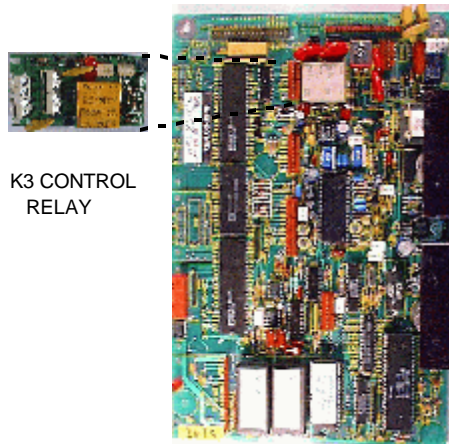

K3 CONTROL RELAY

The optional (OPTK3R) K3 relay is a control & alarm relay module. The control relay is used to control a device any time the TEC is

taken off hook. Applications for the control relay of this option include using CCTV equipment with the TEC, or controlling lighting that turns on whenever the TEC is being used for communications.

The alarm relay turns on immediately whenever either tamper input on the OPTK3R card is closed.

The relay capabilities are 48 volts AC or DC at 3 amp. Form "A" (N/O) or form "B" (N/C) contacts are on the control output relay for controlling devices. These are jumper selected (see right).

Note that jumpers for relay selection must be moved in pairs. This is to provide sufficient current capacity for the controlled device.

If additional current capacity is required, it is recommended that the control relay be used to control a larger relay or contactor. For further questions, consult the factory.

The two tamper signal inputs are "dry" contact input only. These inputs are normally open and actuate the alarm relay upon contact closure. To simplify troubleshooting in the field, an LED indicator lights whenever the input signal is closed.

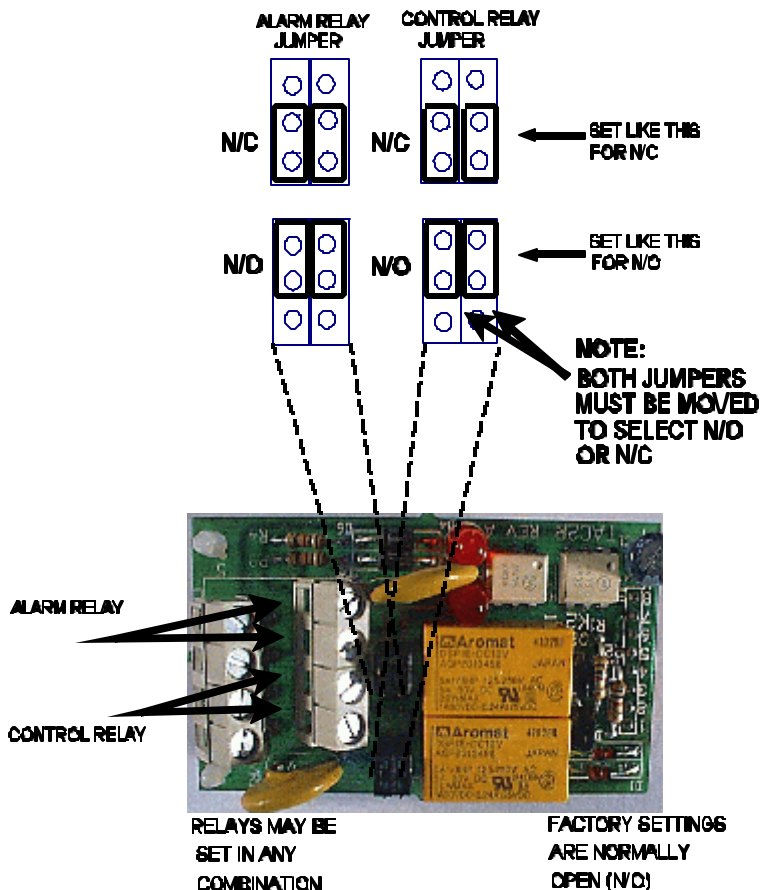

LEDS TURN ON WHEN INPUT IS CLOSED

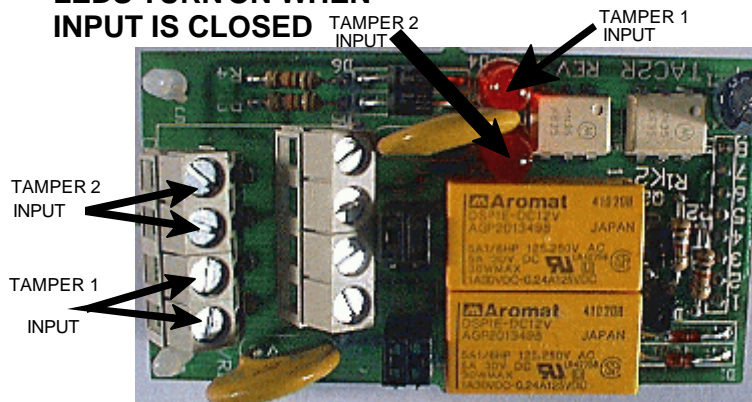

NOTE: TAMPER INPUT SIGNALS REPORT "CLOSED" AND "OPEN" STATES TO THE LOGGING PRINTER.

13.1 K3 AS A THIRD ENTRANCE

To enable K3 as a third entrance, the alarm time is set to 00. See section 4.2.3.2 in the Installation manual. Since the alarm has no time, the TEC II knows that the off hook control function, and the alarm output function are no longer required.

Select "3" from the main menu. Press the "r" key from the front door key pad, or the <Enter> key from a keyboard.

Select "2" from this sub-menu. You will be prompted to select alarm time. Set the alarm time to 00. Press the "r" key from the front door key pad, or the <Enter> key from a keyboard.

Going to the Entrance Control menu will now display three choices instead of two, for Entrance Control.

ALARM TIME =00

13.2 ENTRANCE 3 PROGRAMMING

13.2.1 ENTRANCE 3 UNLOCK TIME

Press "2" from the main menu, then "3" from the Entry Control menu, then "1" to set the time in seconds from 1 to 99 seconds. This is the length of time the door control relay for door 1 will be energized. The factory default is 10 seconds. A good rule of thumb for entry time is 3 seconds plus 2 seconds for every step from the TEC to the entrance being controlled. To change time, key in the time desired and press the "r" key. You will be returned to the Entry Control menu.

Press "r" and "0" simultaneously to escape out of these menus and return the TEC to normal operation, or a "r" to return to the previous menu.

**ENT 3
UNLOCK TIME = 10**

13.2.2 ENTRANCE 3 UNLOCK TONE

The Entrance 3 tone refers to the Touch-Tone™ number from a telephone that must be pressed to energize the door control relay. This relay will be energized for whatever length of time was selected (see section 4.2.2.6; door open time). To change the number from the default setting of 0 (disabled) to another number, press "2" from the ENT 3 Control menu. Select the new number (from 1 - 9) and press the "r" key. You will be returned to the Entrance Control menu.

SELECTING A "0" DISABLES ENTRANCE 2 UNLOCK TONE FEATURE.

**ENT 3
UNLOCK TONE = 0**

13.2.3 ENTRANCE 3 AUTO GROUP

The Entrance 3 Auto Group refers to the group of Access levels and time zones that allow the entrance to automatically open on given days for the hours that match the time zone programmed. . To change the number from the default setting of 0 to another number, press "3" from the ENT 3 Control menu. Select the new number (from 0 - 7) and press the "r" key. You will be returned to the Entry Control menu. **SELECTING A "0" DISABLES THE ENTRANCE 3 AUTO GROUP FUNCTION.** Selecting a number from 1 - 7 allows that number to automatically open the door on the days and times set for that group.

**ENT 3
AUTO GROUP = 0**

NOTE: AUTOMATIC UNLOCK/RE-LOCK (AUTO GROUP) OVERRIDES ANY OTHER LATCH CONTROL.

13.2.4 ENTRANCE 3 LATCH TONE

**ENT 3
LATCH TONE = 0**

The ENT 2 latch tone refers to the Touch-Tone™ number from a telephone that must be pressed to energize the entrance control relay. Unlike the Entrance 3 unlock tone that was timed, this relay will be energized (or latched) until called back and unlatched. To unlatch a door that has been latched, use the Entrance 3 unlock tone, which will relock the door after time out. To change the number from the default setting of 0 to another number, press "4" from the ENT 3 Control menu. Select the new number (from 0 - 9) and press the "r" key. You will be returned to the ENT Control menu. **SELECTING A "0" DISABLES THE LATCHING FUNCTION.** Selecting a number from 1 - 9 allows that number to latch the Entrance 3 relay when you call the TEC.

NOTE: IF ENT 3 TONE AND ENT 3 LATCH ARE THE SAME NUMBER, THE ENT 3 RELAY WILL NOT LATCH OR TIME OUT. IT WILL ENERGIZE BRIEFLY, AND THEN DE-ENERGIZE.

13.2.5 ENTRANCE 3 AJAR TIME

**ENT 3
AJAR TIME = 20**

Press "5" from the ENT 3 Control menu to set the ajar time in seconds from 1 to 99 seconds. The factory default is 20 seconds. To change time, key in the time desired and press the "r" key. You will be returned to the Entry Control menu. The door ajar timer may be used with a normally open sensor such as a magnetic reed switch connected to the door. Wire this to the door sense input on the OPTK3R module (See section 13.2.6 Pg. 53) After the door control relay is energized, opening the door causes a contact closure across the door sense input. This de-energizes the door control relay (causing a re-lock when the door closes). After door open time out, the ajar timer begins. If the door is not closed before the ajar timer times out, an ajar alarm can occur. Five seconds after the ajar timer times out, the shunt relay on the OPTK2R module will de-energize. If the optional alarm relay (OPTK3R) is installed, it will energize at this time.

Press "r" and "0" simultaneously to escape out of these menus and return the TEC to normal operation, or a "r" to return to the previous menu.

LEDS TURN ON WHEN INPUT IS CLOSED

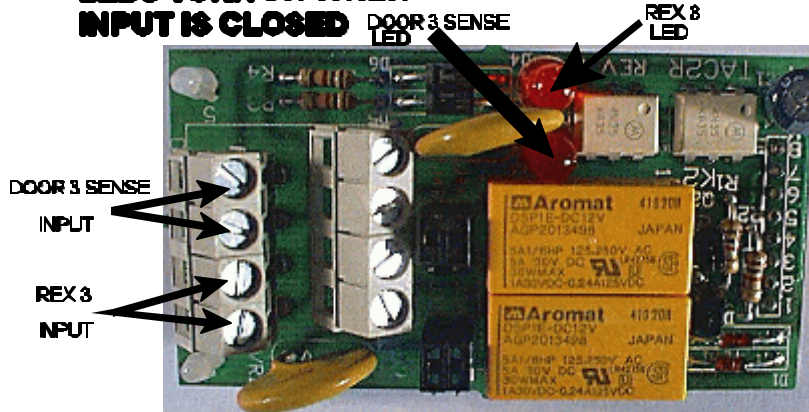

13.2.6 ENTRANCE 3 WIRING

The relay capabilities are 48 volts AC or DC at 3 amp. Form "A" (N/O) or form "B" (N/C) contacts are on the control output relay for controlling devices. These are jumper selected (see left).

Note that jumpers for relay selection must be moved in pairs. This is to provide sufficient current capacity for the controlled device.

If additional current capabilities are required, it is recommended that the control relay be used to control a larger relay or contactor. For further questions, consult the factory.

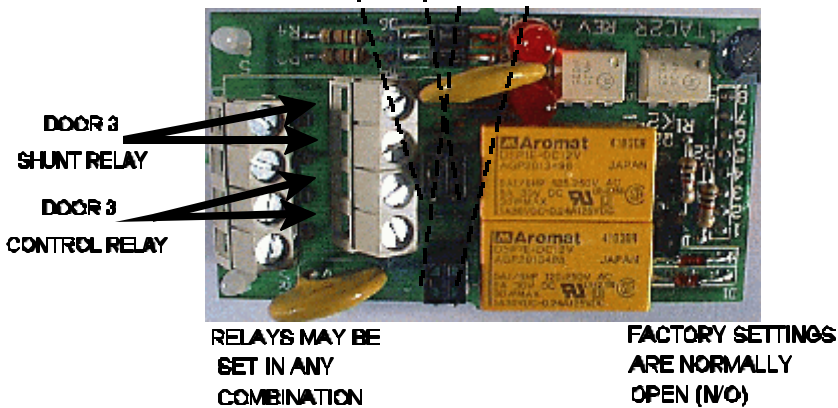
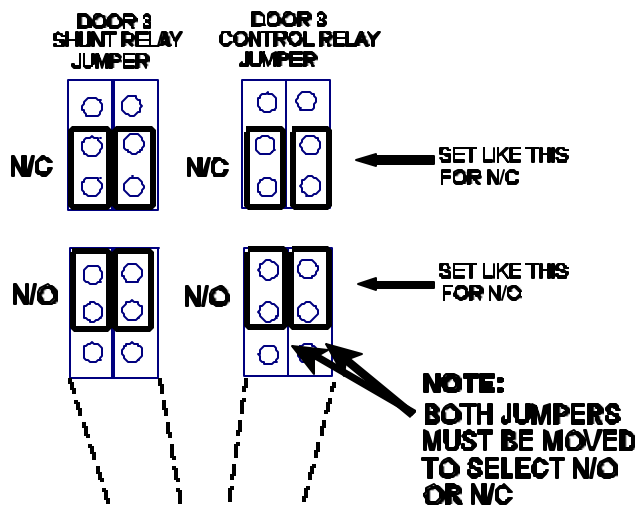

The door sense signal input and the REX (REquest to eXit) signal input are "dry" contact inputs only. These inputs are normally open and actuate the relay upon contact closure. To simplify troubleshooting in the field, an LED indicator lights whenever the input signal is closed.

After the door control relay is energized (that also energizes the alarm shunt relay), opening the door causes a contact closure across the door sense input. This de-energizes the door control relay (causing a re-lock when the door closes. After door open time out, the ajar timer begins. If the door is not closed before the

timer times out, an ajar alarm can occur. Five seconds after the ajar alarm times out, the alarm shunt relay will de-energize.

14.0 SERIAL PORT ADAPTER

14.1 PRINTER

The optional RS-232 serial port adapter (OPTKPRT) may be used to send information from the TEC to a serial printer. Information may be transmitted to the printer at rates from 300 baud to 19200 baud. Baud rate may be selected from the communications setup menu. Because TEC printer messages are relatively short, a busy signal control is usually not required. The busy signal is only active for systems that have a transaction buffer (See section 4.2.7). If the BSY signal is used it can be inverted from high going to low going as required by some printers by removing jumper J-3. The only connections usually required for a printer are RX (Received Data, pin 3) and GROUND (pin 7).

Connect the TX terminal on the serial port adapter to the input of the printer. It may be called RX, RCV, Data In, or some other label. Connect the serial port adapter ground to printer ground (may also be called common).

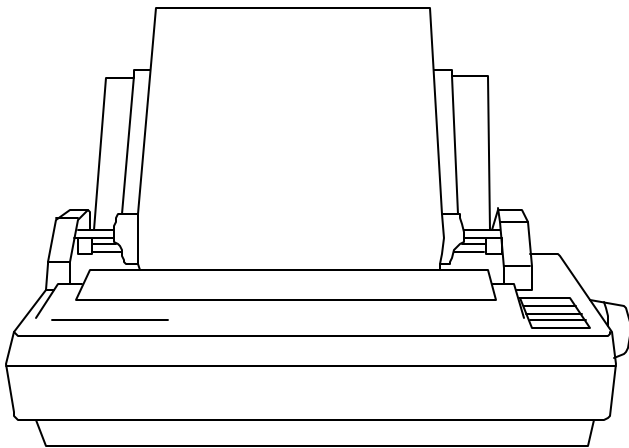

THE PRINTER SHOULD BE SET TO 8 BITS, NO PARITY BIT, AND 1 STOP BIT (8,N,1).

Consult the manual for your printer to set your printer to these parameters. SES has an optional printer that is set correctly at the factory. Because of the wide variation in printers on the market, SES cannot make specific recommendations for printers that are not purchased from SES.

J2 MUST BE JUMPERED

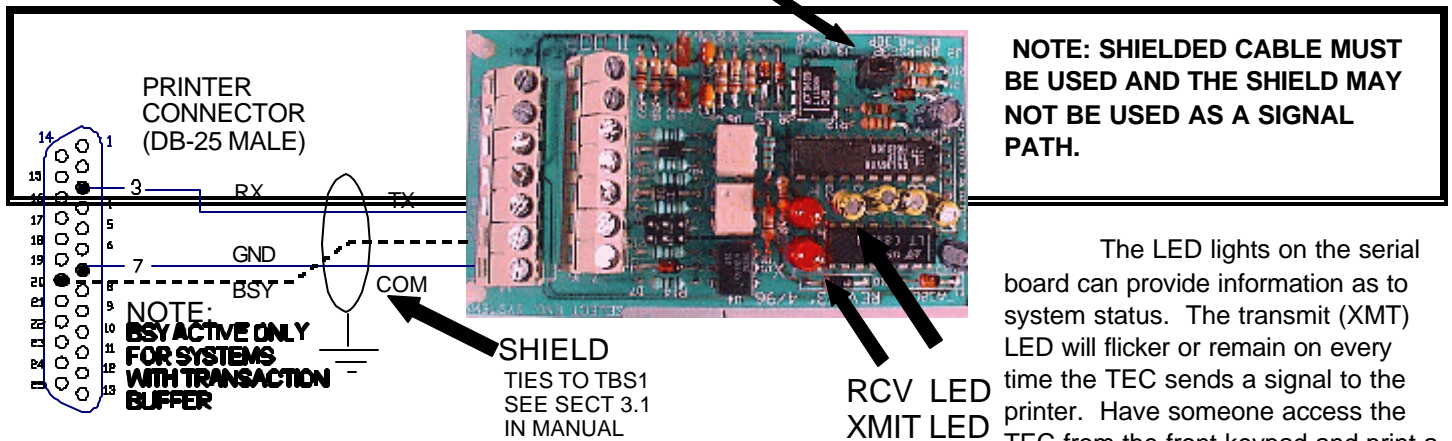

The LED lights on the serial board can provide information as to system status. The transmit (XMT) LED will flicker or remain on every time the TEC sends a signal to the printer. Have someone access the TEC from the front keypad and print a

TECVISION Series v 3.1X

report. While the TEC is transmitting data, the XMT LED will either flicker or stay on (depending on baud rate) while the report prints.

14.1.1 PRINTER REPORTS AND MESSAGES

If a printer is attached to the TEC, and has a Clock Calendar option (OPTKCLK), this start up message will print when the TEC is first powered on.

S.E.S. TEC2

VER 3.XX (where X.XX is a version and revision number)

00:00/00/00 (where 00:00 is the time, and 00/00/00 is the date.

The time and date may not be correct until the time and date are set. See section 4.2.5.1 SETTING TIME DATE to set the clock. If the optional clock has not been purchased, this line will not display.

Some examples of typical logging report messages are shown below.

```
PROGRAMMING MODE ENTERED ON KEYPAD 00:00/00/00
EXIT PROGRAMMING MODE 00:00 00/00/00
ENT 1 LATCHED OPEN BY CLOCK 00:00 00/00/00
ENT 2 LATCHED OPEN BY CLOCK 00:00 00/00/00
CARD 00790 CODE 003 MORRIS, NORMAN ENTRANCE 1 OPEN 00:00 00/00/00
CARD 01291 CODE 002 DAVIS, JIM LEVEL NOT SET READER 2 00:00 00/00/00
CODE 004 SHEPARD, JULIUS DIALED 00:00 00/00/00
CODE 004 SHEPARD, JULIUS ENTRANCE 2 OPEN 00:00 00/00/00
ENT 2 LOCKED 00:00 00/00/00
CARD 00257 CODE 003 DOE, JOHN DAY NOT VALID READER 2 00:00 00/00/00
CARD 00260 CODE 002 CHAVEZ, CAESAR OUTSIDE TIMEZONE READER 2 00:00 00/00/00
CARD 00764 CODE 004 SHEPARD, JULIUS INVALID ENTRANCE 1 00:00 00/00/00
PIN 0001 CODE 001 BROWN, BOB OUTSIDE TIMEZONE ENTRANCE 1 00:00 00/00/00
ENT 1 LOCKED 00:00 00/00/00
CODE 000 PASTOR, JOHN DIALED 00:00 00/00/00
CALLER HUNGUP 00:00 00/00/00
TAMPER 1 CLOSED 00:00 00/00/00
TAMPER 1 OPEN 00:00 00/00/00
PIN 0003 CODE 003 DOE, JOHN DAY NOT VALID ENTRANCE 1 00:00 00/00/00
INVALID CODE 911 ATTEMPTED 00:00 00/00/00
PIN 911 WALLACE, WILL ENTRANCE 1 OPEN 00:00 00/00/00
ENT 1 LOCKED 00:00 00/00/00
INVALID PASSWORD ATTEMPTED KEYPAD 00:00 00/00/00
START PAR ERR READER 1 00:00 00/00/00
INVALID CODE 955 ATTEMPTED 00:00 00/00/00
SITE CODE ERROR 001 READER 1 00:00 00/00/00
EXIT PROGRAMMING MODE 00:00/00/00
```

14.2 CONNECTING A PERSONAL COMPUTER TO THE SERIAL PORT

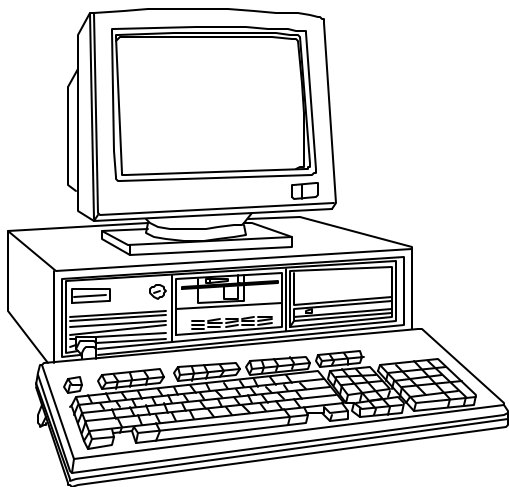

The TEC may be remotely programmed by IBM compatible personal computers that already have a terminal communications program. Set the communications parameters to 9600 baud, 8 bits, 1 stop bit, No parity, (8,N,1) going from the COMM port on your computer to the serial board on the TEC. Check the TEC from the keypad on the front of the TEC to make sure that the TEC communications parameters are also set to 9600 baud. If your software supports terminal emulation, set it to VT-100B emulation. If it does not, program the TEC terminal type in section 4.2.4.1 from VT-100B to "dumb" terminal mode.

To start communications press the "Esc" (escape) key on your computer.

Do not press any other keys until this prompt appears on the CRT screen of your personal computer:

PASSWORD

You have 10 seconds to begin entering the password. If you wait more than 10 seconds before entering the password the TEC will revert back to normal operation and you will have to re-enter the "Esc" key again. All TEC systems leave SES with a factory password of 777777. As the password is entered, the screen will replace each character with an "r" to keep the password confidential. After the password is entered, the main menu will be displayed.

If more than 60 seconds elapse without a keystroke, the TEC will disconnect. It will then be necessary to press "Esc" (escape) and start again.

NOTE: SHIELDED CABLE MUST BE USED AND THE SHIELD MAY NOT BE USED AS A SIGNAL PATH.

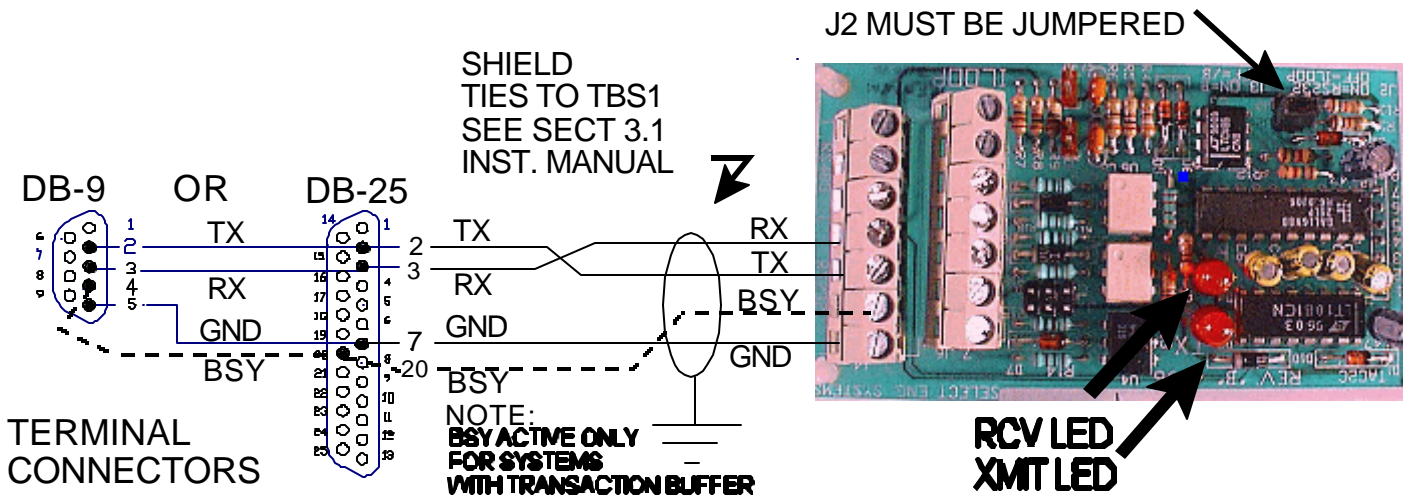

If you have any problems getting the "PASSWORD" message on your personal computer, it may be necessary to check your personal computer's operation. The best way is to remove the TX and RX wires from the TEC serial port adapter and temporarily connect them together. This is called "echo" or "loop back" and will verify terminal connections. While operating the terminal software program, pressing a character on the terminal should echo the same character to the screen. Now re-check this by disconnecting the TX and RX wires, and echoing a character. This time, nothing should echo to the screen.

Until you can verify this operation, there is no need to connect the personal computer to the TEC serial board. The most common problems are either wiring disorders or incorrect COMM port selection in the software used by the personal computer.

Once "loop back" has been verified, the LED lights on the serial board can provide information as to system status. The receive (RCV) LED should flicker briefly every time a keystroke is sent from the personal computer keyboard. The transmit (XMT) LED will flicker or remain on every time the TEC sends a signal to the personal computer screen. Have someone access the TEC from the front keypad and print a report. The XMT LED will stay on for the duration of the report.

14.3 TERMINAL

Connecting a terminal to a Tec series unit is similar to connecting a personal computer. The diagram below shows the connections necessary to operate most CRT terminals with a TEC. Connect ground to the CRT terminal ground. Connect TX from the serial adapter port to RX of the CRT terminal. Connect RX from the serial port adapter to TX of the CRT terminal.

The communications parameters for the terminal to communicate with the TEC are: 8 bits, No parity, 1 stop bit (8, N,1). If your terminal supports emulation modes, set the emulation to VT-100B. If it does not, program the TEC terminal type in section 4.2.4.1 from VT-100B to "dumb" terminal mode. The TEC leaves SES set at 9600 baud. Set your terminal to this speed. Belden cable # 9925 (or equivalent) can be run for distances up to 100 feet. For greater distances, consult factory.

After the terminal is connected and powered on, press the escape key <Esc> once. This prompt will appear on the CRT screen:

PASSWORD

You have 10 seconds to begin entering the password. If you wait more than 10 seconds before entering the password the TEC will revert back to normal operation and you will have to re-enter the "Esc" key again.

All TEC systems leave SES with a factory password of 777777. As the password is entered, the screen will replace each character with an "r" to keep the password confidential.

After the password is entered, the main menu will be displayed.

NOTE: SHIELDED CABLE MUST BE USED AND THE SHIELD MAY NOT BE USED AS A SIGNAL PATH.

If you have any problems getting the "PASSWORD" message on your terminal, it may be necessary to check your terminal's operation. The best way is to remove the TX and RX wires from the serial port adapter and temporarily connect them together. This is called "echo" or "loop back" and will verify terminal connections. Pressing a character on the keyboard should echo the same character to the screen. Now re-check this by disconnecting the TX and RX wires, and echoing a character. This time, nothing should echo to the screen. Until you can verify this operation, there is no need to connect the terminal to the TEC serial board.

Once "loop back" has been verified, the LED lights on the serial board can provide information as to system status. The receive (RCV) LED should flicker briefly every time a keystroke is sent from the terminal. The transmit (XMT) LED will flicker or remain on every time the TEC sends a signal to the terminal. Have someone access the TEC from the front keypad and print a report. The XMT LED will stay on for the duration of the report.

Some terminals have hardware "handshaking" signals that need to be connected in order to achieve proper operation. Refer to your terminal manual for correct connections. The drawing below shows the most common configuration for terminals, and may be of some use if information for your terminal is not available. The BSY (busy) signal is active only for systems that have purchased the optional transaction buffer (OPTXBUF). Due to the large number of terminals on the marketplace, SES is unable to provide technical support for terminals not purchased from SES.

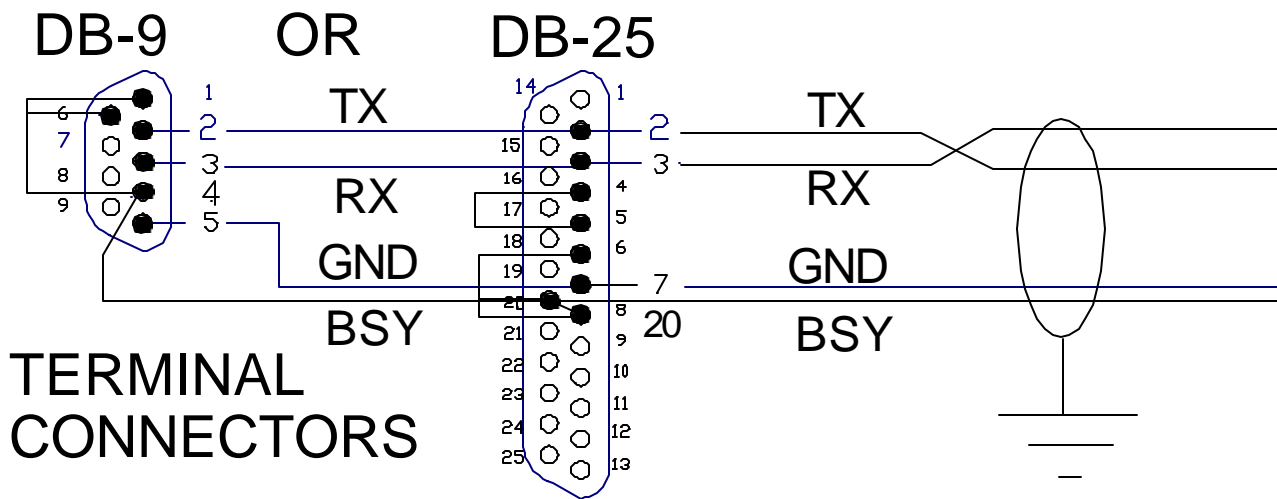

14.4 CURRENT LOOP

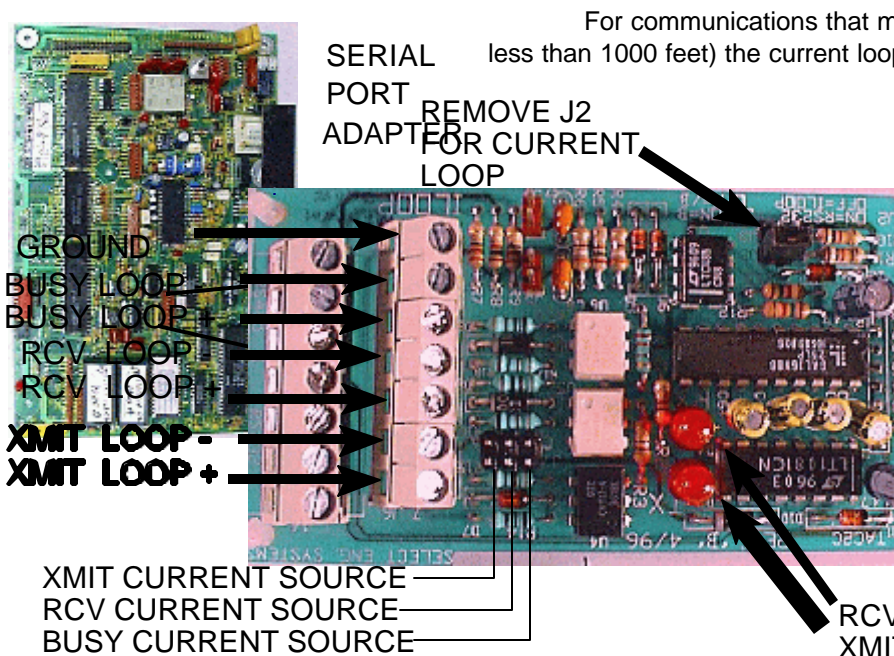

For communications that must occur a longer distance than 100 feet, (but less than 1000 feet) the current loop may be used instead of the RS 232 signals.

The three loops supported are the busy loop, the receive loop and the transmit loop.

Because TEC printer messages are relatively short, a busy signal control is not usually required. The busy loop is only active for systems that have a transaction buffer (See section 4.2.7). The ground and the transmit loop are the only signals usually required for a printer. Information may be transmitted to the printer at rates from 300 baud to 9600 baud. Many serial printers that support current loop, restrict the speed to 1200 baud. Baud rate may be selected from the communications setup menu (see 4.2.4.2).

If you have any problems getting the "PASSWORD" message on your terminal, it may be necessary to check your terminal's operation. The best way is to remove the TX and RX wires from the serial port adapter and temporarily connect them together. This is called "echo" or "loop back" and will verify terminal connections. Pressing a character on the keyboard should echo the same character to the screen. Now re-check this by disconnecting the TX and RX wires, and echoing a character. This time, nothing should echo to the screen. Until you can verify this operation, there is no need to connect the terminal to the TEC serial board.

Once "loop back" has been verified, the LED lights on the serial board can provide information as to system status. The receive (RCV) LED should flicker briefly every time a keystroke is sent from the terminal. The transmit (XMT) LED will flicker or remain on every time the TEC sends a signal to the terminal. Have someone access the TEC from the front keypad and print a report. The XMT LED will stay on for the duration of the report.

Some terminals have hardware "handshaking" signals that need to be connected in order to achieve proper operation. Refer to your terminal manual for correct connections. The drawing below shows the most common configuration for terminals, and may be of some use if information for your terminal is not available. The BSY (busy) signal is active only for systems that have purchased the optional transaction buffer (OPTXBUF). Due to the large number of terminals on the marketplace, SES is unable to provide technical support for terminals not purchased from SES.

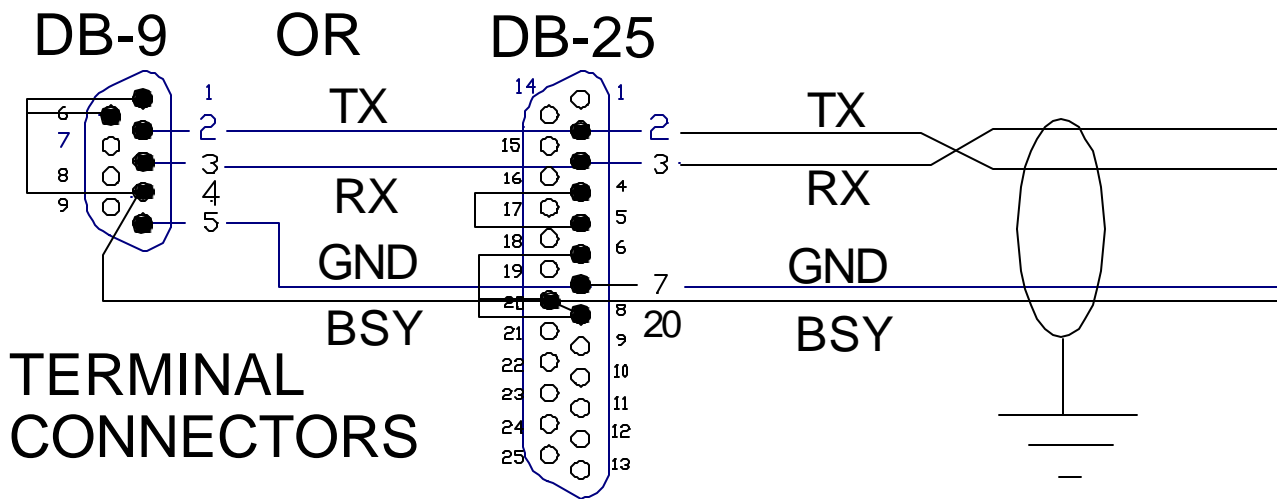

14.4 CURRENT LOOP

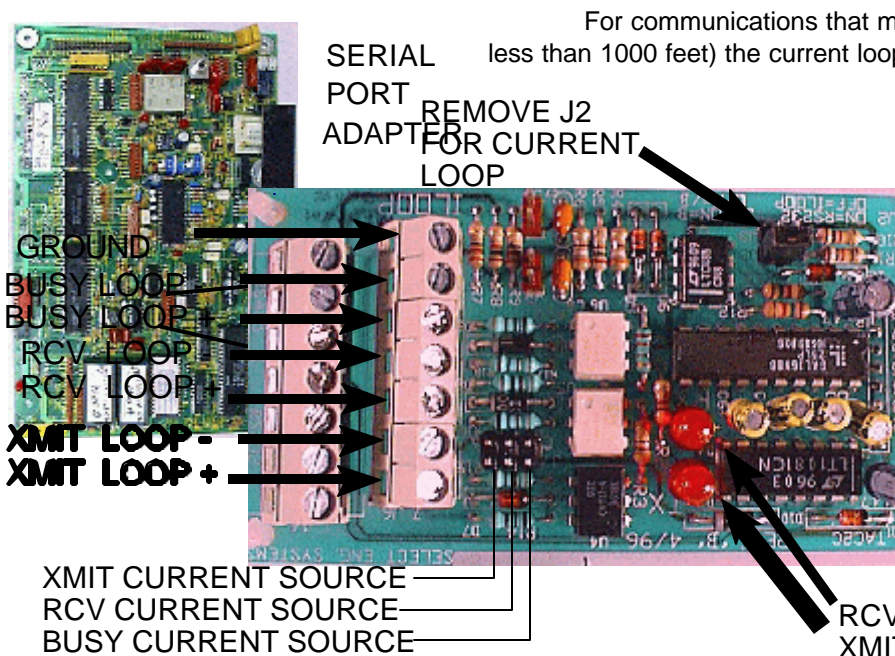

For communications that must occur a longer distance than 100 feet, (but less than 1000 feet) the current loop may be used instead of the RS 232 signals.

The three loops supported are the busy loop, the receive loop and the transmit loop.

Because TEC printer messages are relatively short, a busy signal control is not usually required. The busy loop is only active for systems that have a transaction buffer (See section 4.2.7). The ground and the transmit loop are the only signals usually required for a printer.

Information may be transmitted to the printer at rates from 300 baud to 9600 baud. Many serial printers that support current loop, restrict the speed to 1200 baud. Baud rate may be selected from the communications setup menu (see 4.2.4.2).

TECVISION Series v 3.1X

For current converters that are not active current sources, a current source may be selected from the board by placing a jumper (for example, a jumper on J7-A for the transmit signal) at J-7. This will provide a current loop source of approximately 20 ma. for a maximum distance of 1000 feet. Each signal that needs a current source requires a jumper as shown at left.

NOTE: SHIELDED CABLE MUST BE USED AND THE SHIELD MAY NOT BE USED AS A SIGNAL PATH.

A recommended cable is Belden # 8770. The shield connects to the ground lug on the terminal barrier strip inside the TEC housing (see section 3.1 CONNECTIONS).

Whenever a signal is transmitted from the TEC to the printer the lower TX (transmit) LED will blink briefly. The transmit and receive LED's should help in connecting and troubleshooting serial port connections.

For use as a terminal, the transmit (XMIT) and receive (RCV) loops must be connected to the appropriate current loop converter. For terminals that require a busy signal the optional BSY signal will not be available unless the optional transaction buffer has been purchased.

After the terminal is connected and powered on, press the escape key <ESC> once. This prompt will appear on the CRT screen:

PASSWORD

You have 10 seconds to begin entering the password. If you wait more than 10 seconds before entering the password the TEC will revert back to normal operation and you will have to re-enter the "Esc" key again. All TEC systems leave SES with a factory password of 777777. As the password is entered, the screen will replace each character with an "r" to keep the password confidential. After the password is entered, the main menu will be displayed.

15.0 1200 BAUD MODEM

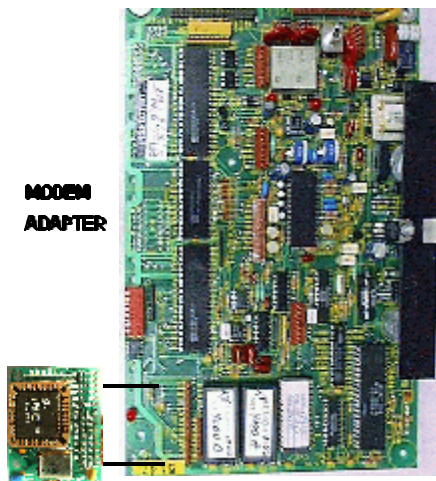

The modem adapter (OPTKMOD) is generally ordered at the same time as the TEC.

To install a modem on the TEC after the TEC has been purchased, toggle the power switch off (or remove the power connector) on the TEC. Next, plug in the modem making sure that both connectors are seated correctly and the nylon standoffs are connected to the main PC board. Then, toggle the power switch on (or reconnect the power connector). The modem operates at 300 and 1200 baud. 1200 baud is the preferred operating speed, but for noisy phone line or difficult communications, 300 baud may be used.

The communications protocols for the modem are: 1200 baud, 8 bits, 1 stop bit, No parity (8,N,1). This modem conforms to Bell 103 and Bell 212A requirements for 300 and 1200 baud.

15.1 9600 MODEM COMMUNICATIONS

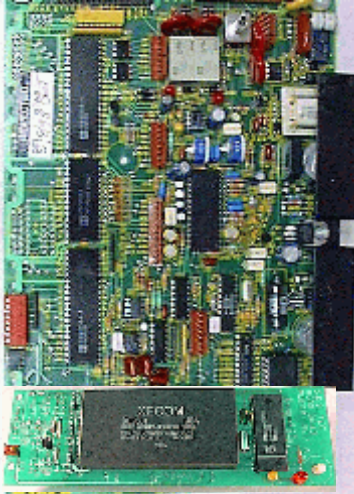

MODEM
ADAPTER

The 9600 baud modem adapter (OPTKMODEM96) is generally ordered at the same time as the TEC.

To install a modem on the TEC after the TEC has been purchased, toggle the power switch off (or remove the power connector) on the TEC. Next, plug in the modem making sure that both connectors are seated correctly and the nylon standoffs are connected to the main PC board. There is an additional standoff in the lower right corner of the PC board that also has to be mounted. Connect the phone line connector cable at the left edge of the board to Terminals TBS-2 and TBS-3 on the terminal barrier strip to the left of the PC board. This is where the existing phone line to the TEC is also connected. Then, toggle the power switch on (or reconnect the power connector). The modem operates at 300 through 9600 baud. The communications protocols for the modem are: 9600 baud, 8 bits, 1 stop bit, No parity (8,N,1).

15.2 MODEM COMMUNICATIONS

The TEC modem functions like any other modem. It can be called from a personal computer that has its own modem (either external or internal), and uses some form of terminal communications program, or a CRT terminal connected to a modem.

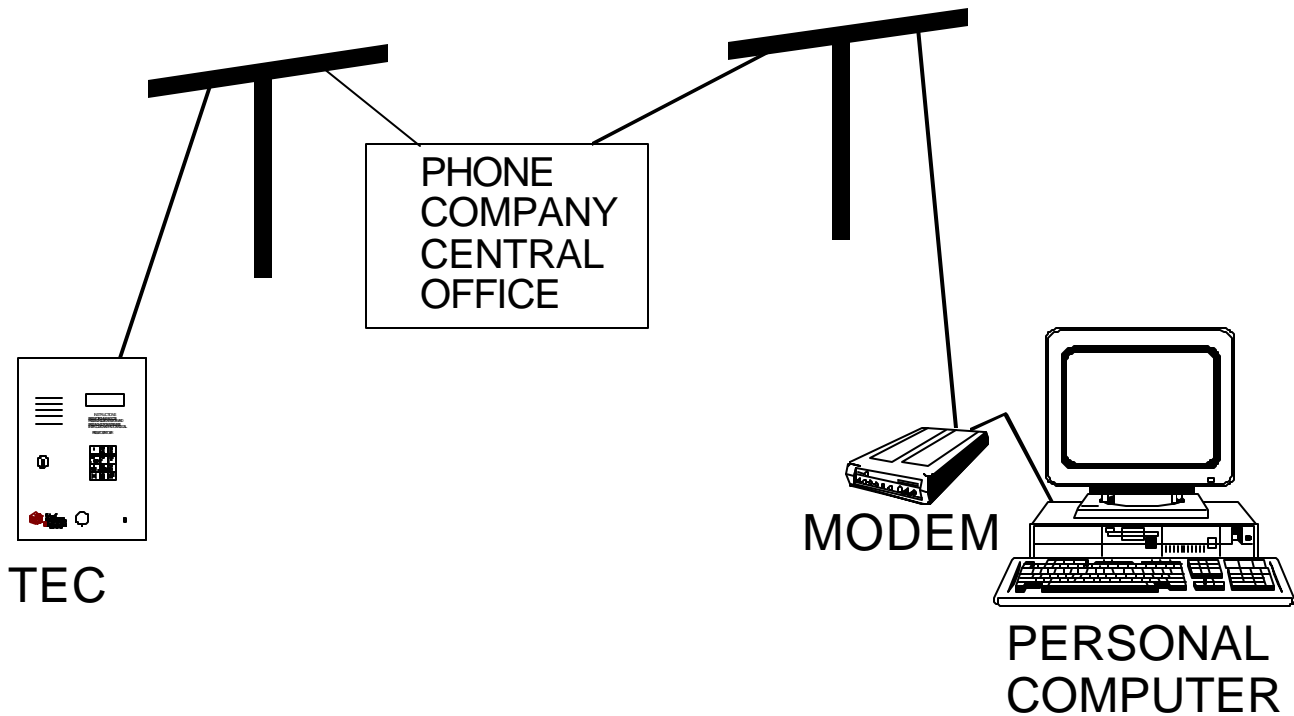

For computers equipped with Windows 95 or later, the optional Selcom 95 program (SELCOMCDF3R5) may be used to control the Tec series unit. This program has many features, including automatic upload (sending information to the Tec unit) and automatic download (getting information from the Tec series unit).

15.3 COMPUTERS WITH OTHER TERMINAL PROGRAMS

If another terminal communications program is used, interactive control of the Tec is possible, but uploading and downloading of information is not possible. Uploading and downloading requires SelCom 95. Set the terminal communications parameters to 1200 baud, N,8,1 and VT-100 emulation, then call the phone number attached to the Tec. The required dial out prefix for most Hayes™ compatible modems should be ATE1V1S7=90DT and the phone number. If your software supports terminal emulation, set it to VT-100B emulation. If it does not, program the TEC terminal type in section 4.2.4.1 from VT-100B to "dumb" terminal mode. When the personal computer calls the TEC, it will answer after 3 rings (this assumes the factory default of three rings has not been changed). After the modems begin communicating, the message CONNECT 1200 (or CONNECT 9600 for 9600 baud modem) may appear on the screen. If the message CONNECT appears without being followed by 1200, then the modem has dropped down to 300 baud. Either the phone line signals are noisy or your personal computer modem may be capable of only 300 baud. Press the "Esc" (escape) key once.

Next, this prompt will appear on the CRT screen of your personal computer:

PASSWORD

You have 10 seconds to begin entering the password. If you wait more than 10 seconds before entering the password the TEC will revert back to normal operation and you will have to call the TEC again.

All TEC systems leave SES with a factory password of 777777. As the password is entered, the screen will replace each character with an "r" to keep the password confidential. After the password is entered, the main menu will be displayed.

If more than 60 seconds elapse without a keystroke, the TEC will disconnect. It will then be necessary to call the TEC again.

In order to prevent unauthorized persons from accessing the TEC through a phone line the TEC will disconnect if any keys are entered before the PASSWORD appears on the screen. To exit from programming, press the "Esc" (escape) key.

Due to the large number of communications programs, it is not possible for SES to support any terminal communications programs except Selcom 95.

15.4 FAX/MODEMS

Some personal computers use a communications device that can communicate with FAX machines and also with

computers. It is usually called a FAX/MODEM. Some of these FAX/MODEMS send out a signal to test whether the device that answers is a fax machine or a modem. If you have one of those machines and it sends out a FAX test signal, that signal will cause the TEC to immediately disconnect and hang up. This is because the signal sent to the TEC does not comply with Bell 103 or Bell 212A modem protocols. This problem can usually be corrected by sending a dial out prefix for Hayes™ compatible modems. This dial out prefix should be ATE1V1S7=90&G0DT and the phone number. Due to the large number and variety of modems available, SES cannot provide technical support for equipment not purchased from SES.

15.5 TWO-MINUTE LOCKOUT

The TEC modem normally disconnects from the phone line when it receives an escape signal after programming has been started. For multiple TEC installations, that share phone lines (using MUI's) it is necessary to temporarily disable the TEC. This is because modems can not currently share the same phone line (Their signals would interfere with each other). This is handled automatically in SelCom95 software. For users of other terminal programs, to temporarily keep a TEC that has an MUI from responding, instead of exiting programming with an "Esc" (escape) key, use "Ctrl T." This means to press and hold the Control (Ctrl) key followed by the "T" key. (The "T" key may be lower case, it is not necessary to press the shift key).

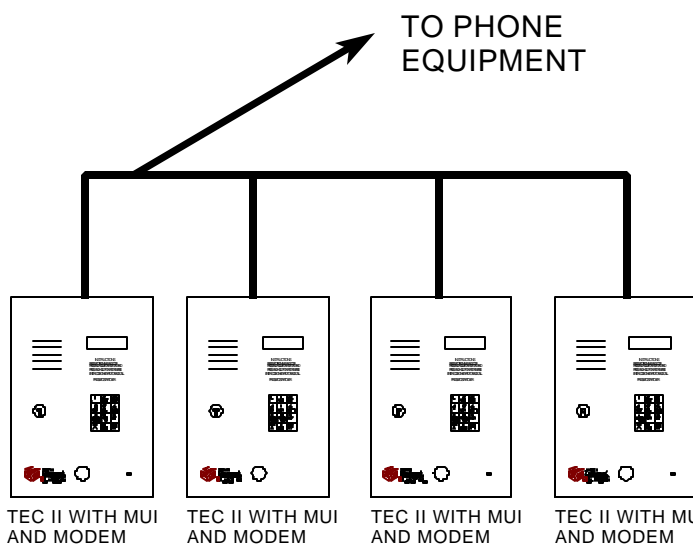

In the example at left, 4 TEC II's (TecVisions could also be used) are sharing a single phone line. The one at the extreme left has had it's ring count set to 2. The next one is set to ring count 4. The 3rd one is set to ring count 6, and the last one is set to ring count 8. This is the number of rings the TEC will listen to before it answers. To program the 1st TEC, call it from your computer (or terminal) equipped with a modem. It will answer after the 2nd ring. After programming is completed instead of pressing the "Esc" (escape) key, press "Ctrl T." This will busy out the 1st TEC for up to 2 minutes. Now call the same number again. After 4 rings the 2nd TEC will answer. After programming, exit with "Ctrl T."

Calling back a 3rd time will busy out the first 2 TECs and cause the 3rd TEC to answer after 6 rings. After programming, exit with "Ctrl T." Calling back the 4th time will busy out the first 3 TECs and the 4th TEC will answer after 8 rings. Exit programming with the "Ctrl T" key. After 2 minutes without the phone line in use, all TECs will be ready to be used for normal operation. Users of Selcom 95 can automate this procedure. Check the Selcom 95 instructions.

Section 10.0 on the MUI shows that up to 8 TECs may be connected to a phone line. If TECs are equipped with modems it is recommended that a maximum of 4 TECs be connected to the same phone line. Noise "glitches" on the phone line might be erroneously interpreted as a ring signal by the TEC. This might cause 2 TECs to answer at the same time, which would prevent the modems from operating correctly. This is also why it is important to have at least 2 rings difference on the TEC ring count.

“BETTER TECHNOLOGY MAKES BETTER SYSTEMS”

Last Printing Date

03/03



***Select
Engineered
Systems, Inc.
7991 West 26th Ave.
Hialeah, FL 33016
Toll Free: 1-800-342-5737
In FL: 305-823-5410
Fax: 305-823-5215
www.selectses.com***