

Select Gate 2 USER GUIDE

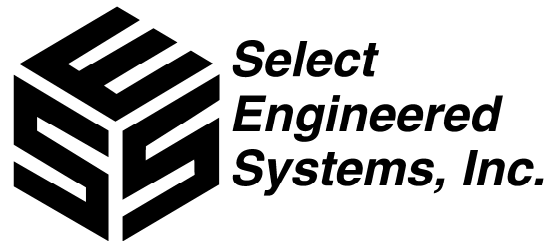

Includes models:
SG-2C, SG-2M



OK, So what IS a SG2?

It's an access control device

So, what does it do?

It prevents or allows (your choice) vehicles and pedestrians to enter through the gate or entrance.

What does it do right out of the box?

Push the big black CALL button and it rings the phones in your house. Push a Touch Tone 6 on your phone and the gate opens.

How does it do that?

Keeps the gate locked until someone calls the house, or uses a card or a PIN code.

What's a PIN code?

It's security jargon for Personal Identification Number. If you use phone calling cards or an ATM; you have used a PIN. It's the same thing, only there is no card involved.

How do I use a PIN code?

You press a * and four digits on the keypad, and if they're the RIGHT 4 digits, in you go!

But, can I use a card too?

Sure, you can use up to 100 of any industry standard 26 bit Wiegand devices, like cards, "clickers" (RF Transmitters), anything that will generate an access device number..

What is Wiegand?

An industry standard for access control devices; your installer will know.

What is a clicker? Is that like the one on my car alarm?

Yes. People call them clickers, but they are actually RF transmitters.

Can I make my car's clicker work for both?

Sorry, no. Auto manufacturers don't make access control equipment and we don't make cars. Actually, our clicker is a little more secure than theirs, anyway.

How many PIN codes can I have?

100

My family's not that big.

Well, we also use these for small businesses. But you can do a lot of things with these PIN codes.

Like what?

Have one PIN open one gate, another PIN open a different gate. Have a PIN that only works on Wednesdays, or Christmas, or almost anything you want.

Only works on Wednesdays? How lame is that?

Not to people that have scheduled deliveries. You can give a PIN to the yard man, or the guy who cleans your pool on Wednesdays and if he tries to sneak in on Saturday, he's out of luck.

Can I do the same thing with Cards or RF Transmitters?

Sure, but those are better left to family members. You can have up to 100 cards, or RF transmitters, too. You can also have PIN or cards "expire" by defining a start and stop date, that the access device number is valid.

How about people who don't have a PIN or a card?

They push that big black CALL button and it rings the house.

How does that work?

You answer any phone on the line, talk to whoever pushed the big black button, then decide if you want to let them in and press a Touch Tone (like 6, for example) on your phone. The gate opens. Simple.

What if I'm already on the phone?

You get a call waiting beep and you press * or # on your phone. This puts whomever you were talking to on hold, and connects you to the gate. After you press the open tone (like # 6, for example), the call switches back to the person on hold and you resume the conversation.

What tone?

Any one you want, except 0. It's programmable. It uses a 6 right out of the box, so push 6 when you get called and the gate opens.

How long will the gate stay open for?

1 to 99 seconds, as set up by your installer.

Can it call other buildings on the property, other than the house?

Sure. It can call up to 10 numbers. You press a number, then #. For example, you might press 3# to call the barn or the ranch hands quarters, or whatever.

I don't have a ranch.

That's OK; it can also be used for small to medium businesses, that want to call up to 10 separate offices.

I have a pretty fancy phone system in my house, how does it work with that?

Pretty good, actually. We designed the SG2 from the bottom up, to make it easy to interface to small PBX systems either as an analog extension or as an unused CO port. Ask your installer, he'll appreciate the versatility.

How about DSL systems for my computer?

Just have your installer follow our installation diagram and you're good to go.

Can I open the SG-2 without being called first, like if I recognize one of my friends at the gate?

Sure, go to a phone, lift up the receiver, wait a second, then press the first two digits of the password, then * then an open tone. Example: 77 * 6

What kind of an open tone?

There are several. You can open the gate for the timed amount (1-99 seconds), or for one hour, or forever. We call that "latched open".

Which tone does what?

Your choice. We set the timed open tone to 6 on an SG-2 but it is programmable for everything except 0 (0 is ignored by SG-2) so if you want 1 to open for a timed amount, 2 to latch open forever and 3 to open for an hour, that's your choice. Just tell your installer what you want. Quick! He's getting in the truck!

Why would I want to "latch" my gate open?

Just to keep the gate open when you have a lot of guests over, for a party or something, so you don't get a traffic jam.

How do I UN-latch a gate, that I latched open?

Same thing you did to latch it open, only this time, use the timed amount tone. By the way, the remote control password ALSO turns on the mike and speaker, in case you need to say something through the SG-2 like: "You kids leave that mailbox alone!"

So if I'm waiting for a delivery, does that mean I'm stuck at the house?

Not with our Select Gate. We have a feature called: call forwarding. When the big black button gets pushed, instead of ringing the house it calls a pre-programmed phone number. Like to the cell phone you're carrying with you, for example. Go do your errand and if the delivery shows up while you're away from the house, you can still open the gate.

I guess I could also call-forward to my office too, huh?

Yes.

Can people call and disturb me at all hours of the day or night, with this thing?

That's up to you. You can make it active 24/7 or you can set up a time schedule, where ONLY during certain hours of the day (or night) will it call the house, when the button is pushed.

Tell me more about this "Time Schedule".

Just like an airline schedule (only, more accurate!), it defines a starting time and an ending time, and some combination of days in the week when something is true. Like Mondays and Fridays from 10 in the morning until 2 in the afternoon, is an example of a Time Schedule. Or Monday through Friday from 9 to 5.

Why would I want a schedule that is true, while I am at work?

Because you could put that time schedule in the call forwarding function, and any calls to the house from the SG-2, would be automatically routed to your office. After you're back home, any calls go directly to the house and you didn't have to do anything to make that happen after you set up the Time Schedule.

How do I do that?

You can program Time Schedules from the keypad on the SG-2. You can also program Time Schedules (as well as any other programmable function) from a Touch Tone phone in your house. You could even get the optional modem and software package and program it from your computer. There is a programming features sheet that has a place for you to fill in the blanks and key in the information. You could get your installer to do it, but it's a LOT easier, with the software.

This must be how some PINs only work on Wednesdays.

Yes, you simply assign a Time Schedule to a PIN (or a card).

How many Time Schedules are there in this thing?

Lots. Time Schedule 0 is 24/7. There are also 7 individually programmable Time Schedules (1 – 7) and two that are combinations: Time Schedule #8 is a combination of Time Schedules 4 and 5. Time Schedule #9 is a combination of Time Schedules 6 and 7.

Why would I want to combine Time Schedules?

We don't know either, but they're there, if you need them! Actually, this is pretty useful to small businesses that want their gates to automatically open in the morning, so employees can get in to a restricted parking lot; then automatically open again in the afternoons, so the employees can go home.

How does a Time Schedule open a gate?

It's called Automatic Unlock. It's the same principle as your porch lights going on at night, or lawn sprinklers coming on, automatically.

What about Holidays?

There is room to define up to 10 Holidays. For small to medium business owners, this can affect the automatic unlock hours on Holidays, when no one is at the facility, with out having to re-program everything, for just one Holiday.

So what else has this thing got?

Another relay, for one thing. That's the gadget that makes the gate work. You could have two different gates open and close from the SG-2C. Or, you can make the second relay come on every time someone calls the house, so you could control a CCTV camera, for example. There are a variety of choices; one of them should work for your needs.

How does a PIN for one gate, make the other gate work?

That's up to you. You can program PINs or cards so that a PIN opens one gate, or the other gate, or both gates, when a PIN code is entered on the keypad. This is called a Relay Action and is on the Programming Sheet. You can also make it only open when a Time Schedule is true. So every single PIN and card can have a Relay Action and a Time Schedule assigned to it.

There's that "Programming" word again. My VCR is still blinking: "00:00" two years after I got it. How do I make this thing do what I want?

You can use the Programming Sheet provided, or you can buy the optional Modem and Software to make life simpler. Contact your installer for details. For example, the software will set the clock automatically from your computer's clock. Your choice. Right out of the box, an SG-2 will call the house and open the gate when it hears a Touch Tone 6. If that is as fancy as you want to get for now, then you don't have to do anything.

Any other bells and whistles?

How about a 800-event log? If you get the optional Modem and Software package, you can keep track of who called the house, when, or used a PIN code, or anything that happened to the SG-2C.

What good does that do a homeowner?

That's up to you. Want to find out when the teenager REALLY got home, last night with the family car? Look in the log. If Junior's card shows a 4 AM time stamp, he's busted!

Guess that's more helpful to a small to medium business owner, huh?

Yes.

Anything else?

Well, there are 4 distinctive phone ringing cadences (short or long rings, etc.) to let you know you are being called from the SG-2, instead of from somewhere else. If you have more than one SG-2 on your property (and oh, by the way, Bless you!) you can set each SG-2 with a distinctive ring. Short Short (out of the box), Short Long, Long Short or Long Long.

How many SG-2s can I have attached to the same phone line?

Up to 4 on the same phone line, but you will have to change their pass codes, in order to program them.

How about if I'm already on the phone, talking to someone else?

The call waiting beeps will alert you; again, using a distinctive tone cadence. (SS, SL, LS, LL)

So this thing can do quite a lot, after all.

Yes, thank you. And we didn't even get into making the keypad active (keys 0–9) after calling the house, or clearing the log, or setting the clock. Play with it a while. Our customers think up LOTS of things for the SG-2 to do.

Ooops!! Troubleshooting the SG-2C/SG2M:

I MEANT to write down my pass code, but I forgot what it is! Now what do I do?

There are two metal pins marked PROG on the SG-2. Touch them together, (might want to have your installer do this) and it will reset the pass code to 7777. Then, change it to whatever you want, using the program sheet. Oh, and write it down this time!

When using the remote control function and entering my passcode, sometimes the phone company message comes on first. Why?

In different parts of the country you may activate the automatic message equipment. This happens if your pass code interferes with an exchange in your area. Just change the first two digits of the pass code, to something your local telephone company computer is happier with.

Select Gate-SG2C/SG2M Installation

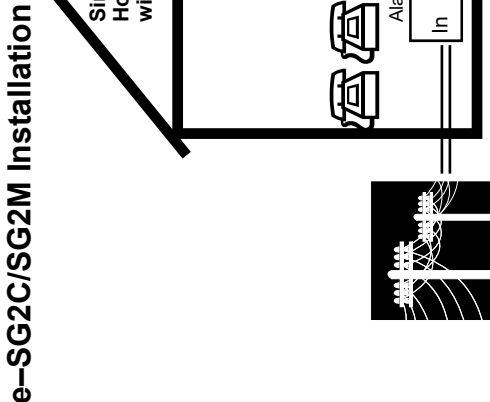
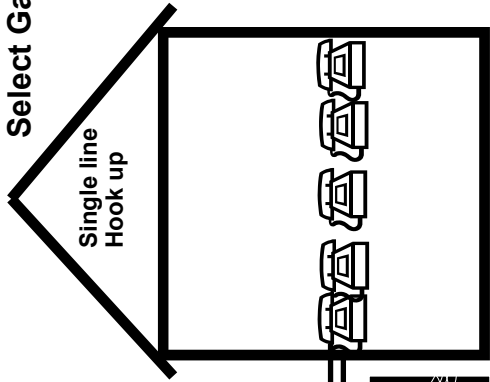
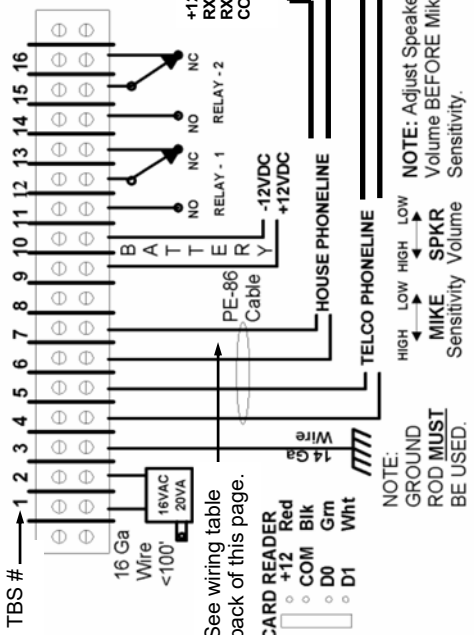

Quick Programming

To get into Program Mode:
Press * and 0 at same time. Hear two beeps.
Press 4 digits of password (7777 factory default).
Hear beep after each key press.
Press *. Hear three beeps.

To Program a Pin code: (Relay 1)
Press 12 00 1234 00 *. (Pin Code = 1234 in loc. 00.)
Press 12 01 5678 00 *. (Pin Code = 5678 in loc. 01.)

To Delete a Pin Code:
Press 12 00 *. (Pin Code 1234 deleted.)
Press 12 01 *. (Pin Code 5678 deleted.)

To Program a Phone Code:
Press 11 0 5551212 *. (Phone# 555-1212 in loc. 0.)
Press 11 1 987654321 *. (Phone# 987 655-4321 in loc. 1.)

To Delete a Phone Code:
Press 11 0 *. (Phone # 555-1212 deleted.)
Press 11 1 *. (Phone # 987 655-4321 deleted.)

To Program Latch Relay: (Relay 1)
Press 22 7 *. (Latch tone = 7.)

To Program Call Forwarding:
Press 61 9 *. (Sets call forward tone to 9)
Press 62 0 *. (Call forwards without alert to house.)
Press 62 1 *. (Call forwards with alert to house.)

To Program Call Forwarding Phone Number:
Press 65 9877654321 *. (Call forwards to 987 765-4321.)

To Enable Call Forwarding: Press 64 1 *

To Program Gate Open Time: (Relay 1)
Press 24 02 *. (Open time = 2 seconds.)
Press 24 13 *. (Open time = 13 seconds.)

To Exit Program Mode: Press * and 0 at same time.
Hear three beeps.

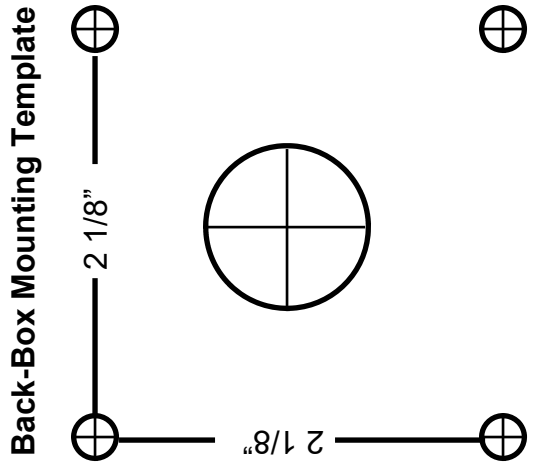
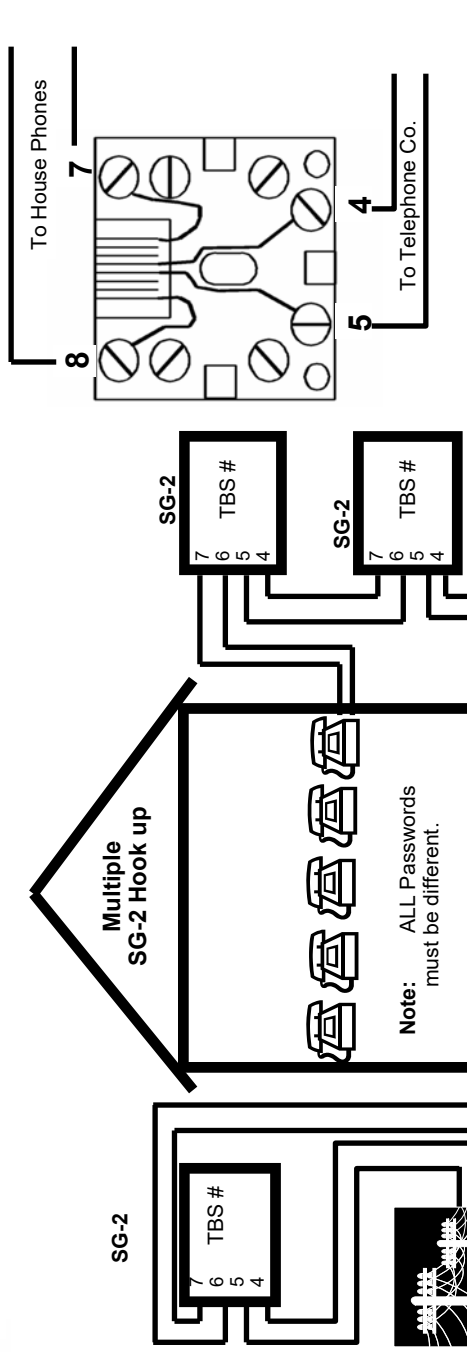

Select Gate-SG2C/SG2M Installation Sheet (Advanced)

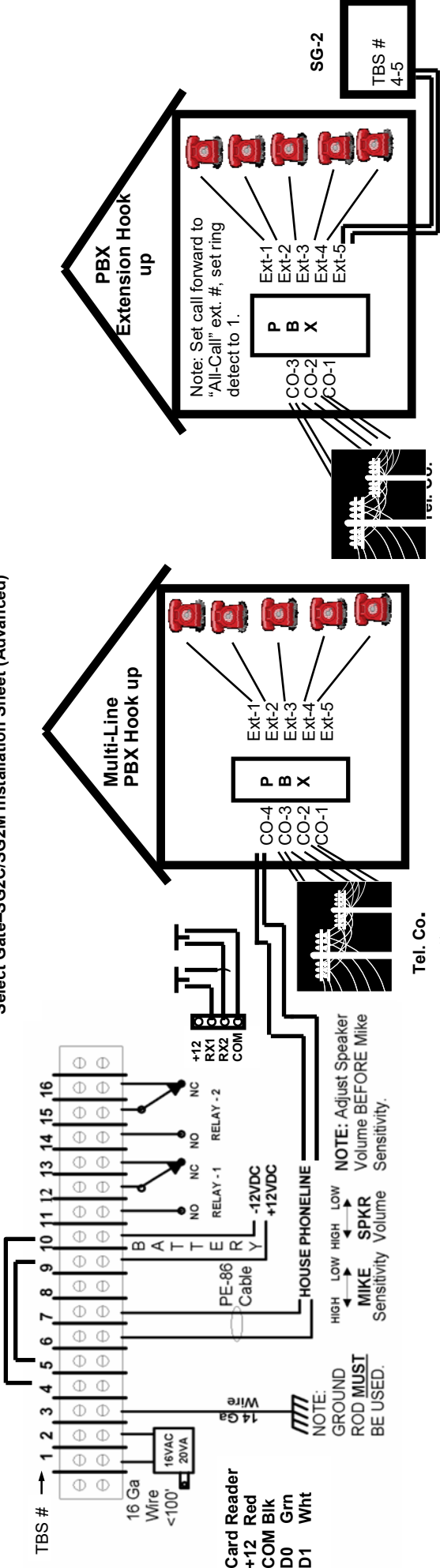

REN (Ringer Equivalence Number) = Number of phones in house that Phone Co. rules say can be rung.
 Total REN value can NOT exceed value of: 5.0
 Look on bottom of instrument, or on equipment label for REN number.

- Typical example:
- 2 old style phones @ 1.0 REN = 2.0
 - 4 new style phones @ .6 REN = 2.4
 - 1 Computer modem @ .2 REN = .2
 - 1 Fax machine @ .2 REN = .2
 - 1 Answering mach. @ .1 REN = .1
- Total REN = 4.9

REN Calculation

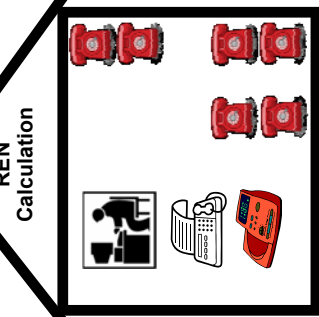

DSL HOOKUP ADDENDUM:

Special DSL wiring and filter considerations are no longer required for the SG2 series. The SG-2C has built-in circuitry to handle DSL signals so as to permit phone conversations without impeding normal DSL operation.

Telephone wiring table.

NOTE: MUST use direct burial rated outside plant wiring in compliance with ANSI/ICEA S-96-634-1996 REA PE-86 or RUS PE-86 requirements.

Wire Mfg	Wire Usage	Wire Type Designation	24 Ga. (Up to 1,000 ft. distance)	22 Ga. (Up to 5,000 ft. distance)	19 Ga. (Up to 10,000 ft. distance)
Superior/Essex	Above Grade	(RUS PE-86) BDW-A	04-098-85	04-055-84	02-023-85
Superior/Essex	Below Grade	(RUS PE-86) BDW-A	04-098-85	04-055-84	02-023-85
Superior/Essex	Gopher/Rodent	(RUS PE-86) BDW-G	04-094-16	04-055-17	04-030-16
General Cable	Below Grade	(RUS PE-86)	2095132	2095126	Not Available
General Cable	Gopher/Rodent	(RUS PE-86)	2095066	2095002	2095102

Card Reader wire/cable table.

- Above grade (recommended installed in pipe): <100 feet: Belden # 9940
- Below grade (Direct burial): <500 feet: Belden # 9883
- Plenum (Fire rated): <500 feet: Belden # 83604

NOTE: Card reader devices that draw > 100 ma. **MUST** use own external ungrounded DC supply.

Alternate powering table and specifications.

- Idle w/LED lighting: 120 ma.
 - Ringing house: 300 ma.
 - Combinations of Solar cell chargers of sufficient current output or Batteries, may be wired into TBS-9 (+ 12 volts) and TBS-10 (- 12 volts) to operate SG-2.
- NOTE: ANY charging devices (battery charger, etc.) MUST be isolated from earth ground.**

SG-2 or SG2/SG2M Basic programming features

For additional information, see SG User Guide.

To Begin Programming: Press *0 at same time, 4 digits of pass code then *.
 Factory default = 7777 Key Stroke Example: *0 7777 * and SG-2 will beep after each key stroke and then beep 3 times, if entered password is valid. From house, lift handset, dial 7777 *. From outside line, call and key in 7777 * when SG-2 answers.
Fn = Select Gate 2 Programming Function.

Pins 1-100 (Fn 12)
 12 Code XX PIN XXXX Relay Action X Time Schedule X then *.
 Key Stroke Example: 12 01 1234 0 0 * will open with *1234 on relay 1 for timed amount, 24 hrs a day.
 Or: 12 02 5678 3 2 * will open relay 1 & 2 for timed amount with key strokes *5678, on hours or days, that Time Schedule 2 is true.
 Or: 12 03 1289 7 0 * will latch relay 1 on with key strokes *1289 and keep it on, until PIN 1234 is keyed in, to unlatch relay 1.
 If start and stop dates are desired, add start month and day and end month and day after time schedule.
 Key Stroke Example: 12 01 1234 0 0 05 22 07 01 will be valid from May 22 to July 1st. If date not desired, press * after Time Schedule choice.

To remove PIN: 12 Code XX O * Example: 12 01 0 * Removes 1234 from above example.

Cards 1-100 (Fn 13)
 13 Code XX Facility Code XXX Card XXXXX Relay Action X Time Schedule X then *.
 Key Stroke Example: 13 01 0101234500 * means card with facility code 010 on card 12345 will open relay 1 for timed amount, 24 hrs a day.
 Or: 13 67 023 56789 2 1 * means card with facility code 023 on card 56789 will open relay 2 for timed amount, whenever Time Schedule 1 is true.
 If start and stop dates are desired, add start month and day and end month and day after Time Schedule.
 Key Stroke Example: 13 01 01012345 00 05 22 07 01 * means card with facility code 10 and Card# 12345 will be valid from May 22 to July 1st. If date not desired, press * after Time Schedule choice.

To remove Card: 13 Code XX O * Example: 13 01 0 * Removes Card 12345 from above example.

Phones 0-9 (Fn 11)
 11 Code X Phone XXXXXXXXXXXXXXX, then *.
 Key Stroke Example: 11 0 18003425737, then * will call that number when 0# is pushed on Key-pad.
 Or: 11 1 9#13055551212; then * will dial 9, wait 1 second, then dial information, when 1# is pushed on keypad.
 Or: 11 3 18003425737 will dial when 3# is pushed on keypad.
To remove Phone: 11 Number X 0 * Example: 11 1 0 * Removes 555-1212 from above example.

Relay Action Table	Time Schedule Table
0 = Relay 1 open 24/7 (For timed amount.)	0 = 24/7 (Will open at any time.)
1 = Relay 1 for Time Schedule	1 = Value of time schedule 1 See values on other side.
2 = Relay 2 for Time Schedule	2 = Value of time schedule 2 See values on other side.
3 = Relay 1 & 2 for Time Schedule	3 = Value of time schedule 3 See values on work sheet.
4 = Relay 1 on forever (latched open)	4 = Value of time schedule 4 See values on work sheet.
5 = Relay 2 on forever (latched open)	5 = Value of time schedule 5 See values on work sheet.
6 = Relay 1 & 2 on forever (latched open)	6 = Value of time schedule 6 See values on work sheet.
7 = Relay 1 on for 1 hour	7 = Value of time schedule 7 See values on work sheet.
8 = Relay 2 on for 1 hour	8 = Value of time schedule 4 & 5 See values on work sheet.
9 = Relay 1 & 2 on for 1 hour	9 = Value of time schedule 6 & 7 See values on work sheet.

Relay 2 Functions

Fn	Key Strokes	Default
31	Unlock Tone 1—9, 0 = Disabled	31 9 *
32	Latch Tone 1—9, 0 = Disabled	32 0 *
33	1 Hour Unlock Tone 1—9, 0 = Disabled	33 0 *
34	Open Time 01—99 default = 02 sec.	34 02 *
35	Relay 2 Auto open Time Schedule	35 0 *
36	Relay 2 Special Function 0-1 (Turns on when house called)	36 1 *

Relay 1 Functions

Fn	Key Strokes	Default	Example:
21	Unlock Tone 1—9, 0 = Disabled	21 6 *	21 1 * Unlock tone is now 1
22	Latch Tone 1—9, 0 = Disabled	22 0 *	22 4 * Latch tone is now 4
23	1 Hour Unlock Tone 1—9, 0 = Disabled	23 0 *	23 7 * 1-Hour tone is now 7
24	Open Time 01—99 default = 02	24 02 *	24 15 * Relay on for 15 seconds
25	Relay 1 Auto open Time Schedule	25 0 *	25 3 * Door open, if TS3 true.
26	Strike Out Count 0—9,	26 0 *	26 3 * 3 strikes & you're out.
27	Lock Out Time 1—4 minutes	27 0 *	27 2 * Locked out for 2 min.

SG-2 or SG2C/SG2M Advanced programming features For additional information, see SG User Guide.

To Begin Programming:
 Press *80 at same time, 4 digits of pass code, then *.
 Factory default = 7777 Ex. *0 7777 * and SG-2 will beep after each key stroke and then 3 times, if password is valid.
 (Only one beep if NOT valid.)
Fn = Select Gate 2 Programming Function

Call Forward

Fn	Key Stroke	Default
61	61 0 *	
62	62 0 *	
63	63 0 *	
64	64 0 *	

Call Enable Time Schedule
 Allows what hours of day and days of week and holidays that Select Gate 2 is allowed to call the house.

Fn 43 Call Enable Time Schedule 1—9 43 (TS) * 0
 0 = Enabled all the time.
 Case 1: Call Enable = 0 Calls house 24/7
 Case 2: Call Enable = 1 Calls when TS1 is true.
 Case 3: Call Enable = 8 Calls when TS4 or TS5 is true.

Maintenance

Fn 83 Clear Log. 831*
 91 Clear all Phone numbers. 91 1010 *
 92 Clear all PIN Numbers. 92 1010 *
 93 Clear all Card Numbers. 93 1010 *
 94 Set all relays to factory defaults. 94 1010 *
 95 Set System * Password. 95 1010 *
 96 Set Call Forward. 96 1010 *
 97 Clear all Time Schedules. 97 1010 *
 98 Clear all Holidays. 98 1010 *
 99 Clear Everything. 99 1010 *
 Example: 99 1010 * will clear ALL PINs, Phone numbers, Card numbers and set all other functions back to Factory Defaults.

Set Clock

Fn	Min.	Hour	Date	Month	Year
79	MM	HH	DD	MM	YY

Example: To set a time of 2:18 PM on Wednesday the 24th of April 2002, you would key in:
 79 18 14 4 24 04 02 *
Day # Sun. = 1 Wed. = 4 Sat. = 7
 (DW) Mon. = 2 Thu. = 5
 Tue. = 3 Fri. = 6

Set It and Forget It (Change as Required)

Ring Cadence: S=Short, L = Long

Fn	Key Strokes	Default
41	Ring Type 1—4	1=SS 2=SL 3=LS 4=LL 41 1 * 1
42	Ring Count 1—9	42 9 * 9
44	Call Waiting Type 1—4	44 1 * 1
45	Ring Detect 00—99	45 09 * 09
46	Back Beep 0 = Off, 1 = On	46 0 * 0
47	Talk Time 1—9 Minutes.	47 1 * 1
48	Keypad active after calling house (0 = Off, 1 = On)	48 0 * 0
51	Programming Password	51 7777 * 7777

Set Holidays

Fn	H	MM	DD	Key Strokes
78	0			* 780 MMDD *
78	1			* 781 MMDD *
78	2			* 782 MMDD *
78	3			* 783 MMDD *
78	4			* 784 MMDD *
78	5			* 785 MMDD *
78	6			* 786 MMDD *
78	7			* 787 MMDD *
78	8			* 788 MMDD *
78	9			* 789 MMDD *

Example: (New Year's Day) 780 01 01 *

Relay Action Table	Time Schedule Table
0 = Relay 1 open 24/7 (For timed amount.)	0 = 24/7 (Will open at any time.)
1 = Relay 1 for Time Schedule	1 = Value of time schedule 1 See values on work sheet below.
2 = Relay 2 for Time Schedule	2 = Value of time schedule 2 See values on work sheet below.
3 = Relay 1 & 2 for Time Schedule	3 = Value of time schedule 3 See values on work sheet below.
4 = Relay 1 on forever (latched open)	4 = Value of time schedule 4 See values on work sheet below.
5 = Relay 2 on forever (latched open)	5 = Value of time schedule 5 See values on work sheet below.
6 = Relay 1 & 2 on forever (latched open)	6 = Value of time schedule 6 See values on work sheet below.
7 = Relay 1 on for 1 hour	7 = Value of time schedule 7 See values on work sheet below.
8 = Relay 2 on for 1 hour	8 = Value of time schedule 4 & 5 See values on work sheet below.
9 = Relay 1 & 2 on for 1 hour	9 = Value of time schedule 6 & 7 See values on work sheet below.

Set Time Schedule Worksheet

Fn	TS	SH	SM	EH	EM	Su	Mo	Tu	We	Th	Fr	Sa	Su
7	1												*
7	2												*
7	3												*
7	4												*
7	5												*
7	6												*
7	7												*

Use this worksheet to plan what times of day, or days of week, you want to be valid.
 8 Time Schedule 8 is combination of TS-4 & TS-5
 9 Time Schedule 9 is combination of TS-6 & TS-7
 0 Time Schedule Zero is always valid 24/7

Example: Set TS 1 to open from 8:30 AM to 1:15 PM (add 12 to PM numbers) All days and holidays: Keystrokes = 7 1 0830131512345678 * if you make a mistake on any Time Schedule entry, press # and re-enter from beginning.

10/15



Select Engineered Systems, Inc.
7991 West 26th Avenue
Hialeah, Florida 33016
Phone: 800.342.5737
Fax:305.823.5215
www.selectses.com